

UCLA

Alumni
Travel

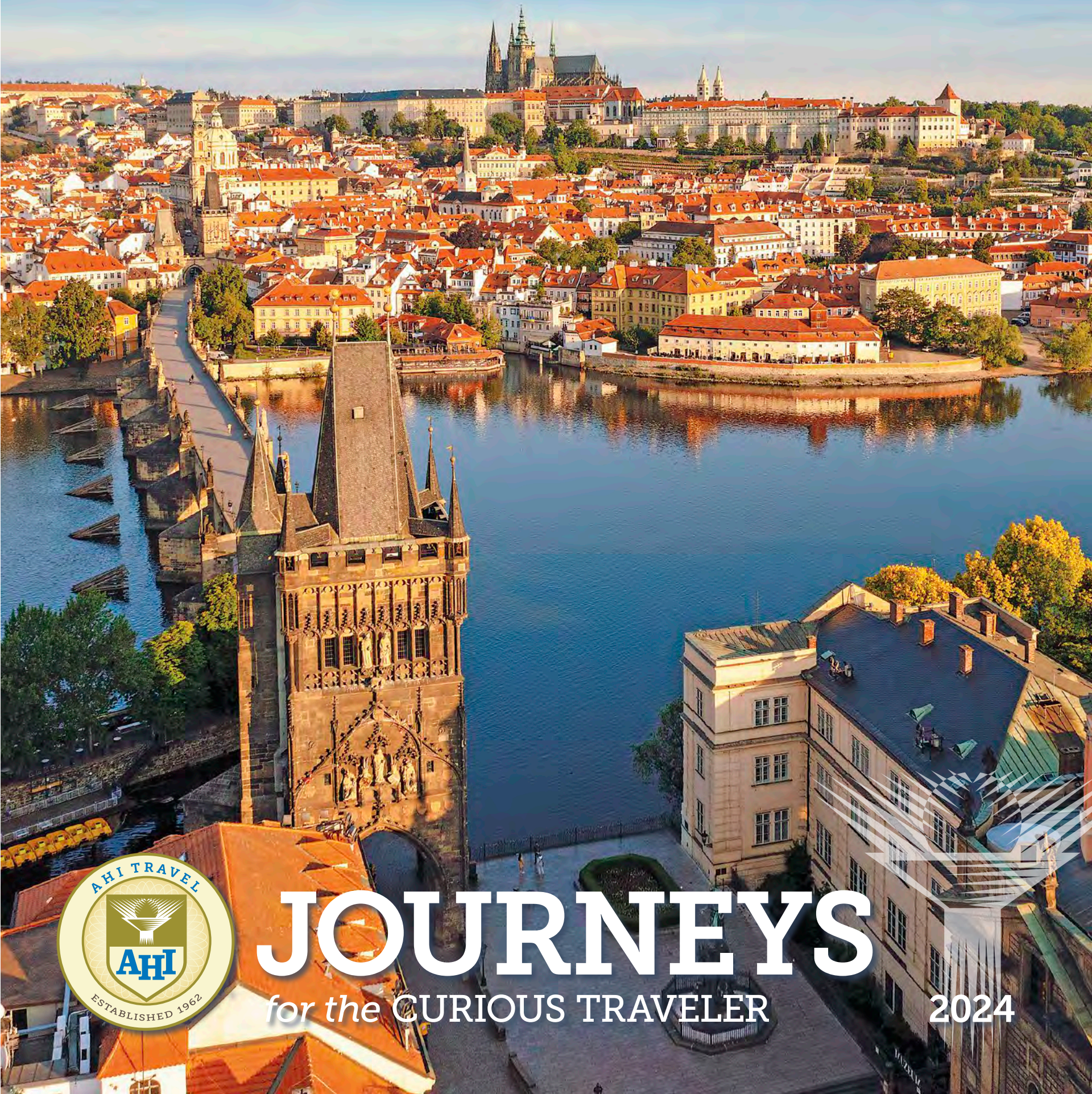

JOURNEYS

for the CURIOUS TRAVELER

2024

Dear UCLA Alumni & Friends,

It's our pleasure to share AHI Travel's 2024 book of journeys, a comprehensive portfolio of exceptional travel programs. You'll find itineraries specially crafted to enrich, inspire and show you the world through a different lens. While browsing this collection, discover adventures that incorporate AHI's signature educational travel, such as the ever-popular Alumni Campus Abroad® programs and intimate Small Group trips. Other traveler favorites include immersive Art, Culture & People experiences and River Journeys along the world's storied waterways.

As always, you'll find more opportunities than ever to customize your experience with a selection of included excursions, as well as elective activities and extensions. In addition, if traveling on your own, look for solo-friendly programs with a waived single supplement fee.

For more than 60 years, AHI Travel's dedicated team has helped travelers explore the world safely and securely. Your well-being remains their highest priority as we continue to stay informed about today's travel landscape.

All tours are accompanied by a professional AHI Travel Director who has extensive knowledge of the destination, giving you extra reassurance.

Let's strike off together and explore the world! Contact us at 310-206-0613 or travel@alumni.ucla.edu for more information. We look forward to welcoming you to the UCLA Alumni Travel and AHI Travel experience.

Regards from Westwood,



Christel Aragon
Director, Alumni Travel

Discovery begins here.



Our AHI Travel Collection



UCLA travelers, South Africa

Personalized Group Travel

Travel Expertise

Meet Some of Our Experts

UCLA Faculty Lecturers

Our Commitment to You

Accommodations

About AHI Programs

LAND JOURNEYS

{ Africa }

Journey to Southern Africa **16**

{ Asia }

Bali, Singapore, Thailand & Angkor Wat **18**

{ Europe }

Finland

Finland | Arctic Magnificence **20**

France

Normandy **22**

Germany & Czech Republic

Grand Cities of Central Europe |
Berlin, Dresden & Prague **24**

Ireland

Coastal Gems of the Emerald Isle |
Wild Atlantic Way **26**

4 LAND JOURNEYS cont'd

5

Italy

6

The Charm of the Amalfi Coast **28**

8

Italy's Magnificent Lake District **30**

10

Tuscany & Emilia-Romagna |

12

A Cultural & Culinary Journey **32**

14

Spain

Spain | Andalucía | In a Parador **34**

{ South America }

Chilean Wonders | Lake District & Patagonia **36**

RIVER & COASTAL JOURNEYS

Croatia & Cruising the Dalmatian Coast **38**

Cruise the Rhine & Moselle Rivers **40**

Dutch Waterways **42**

Grand Danube Passage **44**

Holiday Markets Cruise | The Festive Rhine River **46**

Cruise Pricing & Deck Plans **48**

Extend Your Stay **52**

AHI FlexAir Program **54**

Travel Insider **54**

A Pledge from AHI Travel **55**





Personalized Group Travel

Experience the world while enjoying the value and convenience of group travel.

Creativity. Value. Integrity. Excellence. These are the values that animate our travel programs as we connect you to the people, places and cultures of the world.

Not only is AHI group travel a better value than planning your own trip, but it also allows you access to experiences you could never replicate on your own.



We know you have questions about group travel:

Who else will be on the trip? You will explore with other curious travelers who have interests similar to yours. We often see our travelers become friends and even take future trips together.

Do I have time to explore independently? Our expertly planned itineraries balance group excursions and leisure time.

What makes this program a great value? We deliver fantastic rates due to our longstanding travel partnerships around the world. From the time of booking to your return home, you also have a team of travel experts continuously working to give you optimal value, a bonus not available to the individual traveler.

Our programs feature:

- ▶ Multifaceted itineraries crafted with **inspiring moments** to stir the soul
- ▶ **Outstanding hotels** in the best locations and authentic, regional cuisine
- ▶ **Preferred access** to top sites and hidden gems
- ▶ A **cultural enrichment program**, out of reach to the casual traveler, featuring **local experts** from all walks of life
- ▶ Flexibility to **personalize your journey** on many trips
- ▶ **Free time** to pursue your passions
- ▶ **Carefree travel** while we take care of the logistics
- ▶ A personalized **support team**, including a dedicated Travel Coordinator, to assist you before, during and after the trip
- ▶ The security of traveling with an **experienced travel expert**
- ▶ **Assistance** with independent travel arrangements before and after your trip

Travel Expertise

One of the greatest things about traveling with us is the people who bring your journey to life. From your Travel Coordinator to the Travel Director and lecturers for your program, AHI Travel employs the best people in the industry.



From your reservation to your return home, we are here to ensure you have the adventure of a lifetime.

Before you go:

Travel Consultants | These experts stand ready to answer your questions about activities, meals, accommodations and more as they guide you through the reservation process.

Travel Coordinator | After reserving your spot, enjoy personalized assistance from this specialist, your one point of contact who helps with everything from arranging flights to booking elective activities to fulfilling special requests.

Travel Information | Before your journey, our team closely monitors travel conditions, shares pre-departure details and provides information and enrichment about your destination.



Once you arrive:

On the ground, three layers of top-quality professionals offer their insiders' perspective. Our dedicated team takes your adventure to the next level.

Travel Director | Our multilingual Travel Director manages all the details so that you can simply relax and soak up the ambience. In the care of this seasoned travel professional who is attuned to your personal safety, you'll enjoy a seamless, unforgettable travel experience.

Expert Guides | Who better to show you around than the people who live there? We've specially selected informed, enthusiastic local guides who understand the needs of our educated and curious travelers. Warm and genuine, they're ready to share their passion for their country with you.

Lecturers | Coming from all walks of life, our engaging local lecturers open your eyes to history, culture and current events. The breadth of their knowledge deepens your appreciation for the region and its heritage.



TRAVEL WITH CONFIDENCE

For more than six decades, our dedicated team has helped travelers explore the world safely and securely.

To offer you added peace of mind, we've fine-tuned all facets of your travel experience:

- ▶ Included AHI Travel Assurance plan covers travel- and health-related contingencies; available for U.S. residents only
- ▶ Home support staff and ground team communicating 24/7 to ensure a seamless and safe journey
- ▶ Travel Directors specially trained to the highest standard in accordance with AHI's health and safety protocols
- ▶ Sanitization practices for river ships, hotels, trains and motor coaches

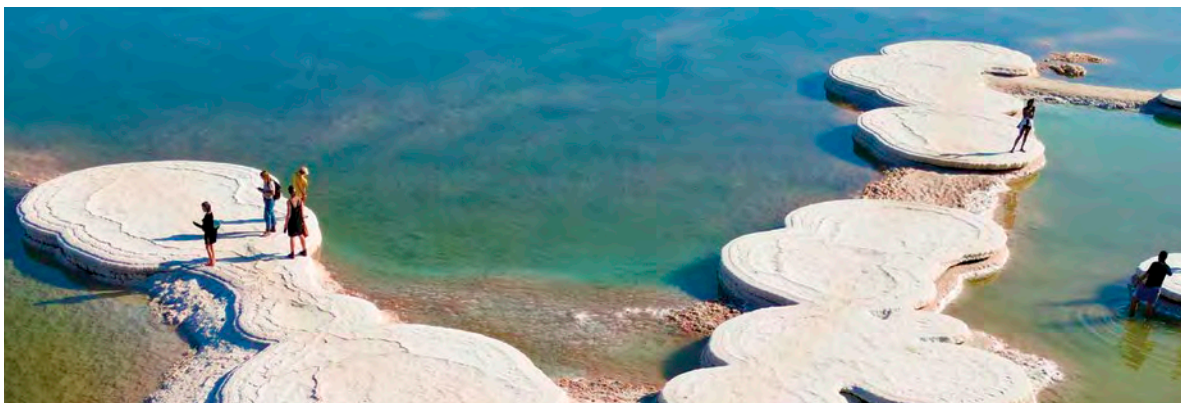

"We returned from our third trip with AHI in October. AHI staff and guides were fantastic. Looking forward to our next alumni trip with AHI."

Chuck | Cruise the Heart of Europe



Meet some of our experts

Our seasoned experts bring your destination to life with firsthand knowledge that reveals the uniqueness of each and every place you visit.

"Our AHI leaders were terrific — so personable, creative and efficient. Our ship was lovely and the food was lavish and abundant (I haven't dared to weigh yet!). Our tour schedule was excellent — a nice balance between restful time on ship and touring the small towns and beautiful countryside."

Wardie | *Romance of the Douro*



Fredrick Burke | Travel Director

As one of AHI's most experienced Travel Directors, Fredrick Burke has guided travelers on programs all over the world. Born into an Air Force family, Fredrick began traveling at a young age. When he finished high school, he joined the Army and hasn't stopped traveling since. Before joining the AHI family, Fredrick led adventure travel groups in the United States, Canada and Mexico. He is fluent in English and French and has a working knowledge of German. Fredrick was born in Delaware and now makes his home in France with his wife and two children. He enjoys skiing, scuba diving, hiking, swimming, biking and traveling.



Fiona Brennan | Travel Director

Born in London, Fiona Brennan now resides in Galway, Ireland. Fiona has worked in the hospitality and tourism industry for over 35 years. For the last eight years, Fiona has enjoyed bringing many a walker along the streets of Galway. Fiona is also recommended by travel guide Rick Steves for her popular walking tours of Galway and holds a Fáiite Ireland Tour Guide badge. In addition to being a Galway specialist, she frequently leads groups along the rivers and canals of Europe. Fiona's hobbies include hill walking, particularly in the Yorkshire Dales, swimming, reading, equestrian sports and looking after her beloved pugs and Maltese dogs.

Featured Expert



John Harrison | Lecturer

An AHI lecturer for many years, John Harrison is also a historian, writer and broadcaster. He lives in Stirling and has a particular interest in the history of the town and the area, but his research has covered many aspects of Scotland's past. Over the last 20 years, John has worked on projects around some of Scotland's major castles. He was a core member of the team which recreated the splendidly refurbished interiors of the childhood home of Mary, Queen of Scots, in Stirling Castle. John was commissioned to write the official book about that project, "Rebirth of a Palace; The Royal Court at Stirling Castle," but he has also a wide range of other publications. His other interests are equally varied, including wildlife, gardening, reading, literature and walking.



Maya Bakhat | Lecturer

Maya Bakhat has been traveling all her life. Born in Morocco, she also lived in Germany and Portugal as a child before settling in Austria, where she currently lives. Maya also has been involved in the tourism industry since she graduated from high school in Vienna. While earning a bachelor's degree in history from the University of Vienna, she worked for a destination management company and also was a travel director for incentive programs and conventions in Europe, Africa and North America. So far, she has guided more than 20,000 travelers! Maya is fluent in English, French and German and can speak basic Spanish, Italian, Arabic, Czech and Hungarian.

Beata Karlikowska Travel Director

A native of Poland and a resident of Kraków, Beata grew up behind the Iron Curtain and willingly shares her knowledge about life during that period. She graduated from the University of Kraków with degrees in marketing and management and a specialization in tourism. Beata has worked as a tour leader and guide for 27 years, leading tours in almost all European countries and many outside Europe. She has worked exclusively for AHI Travel for 18 years. Beata is fluent in Polish, English and Russian and speaks conversational German and Italian. In her spare time, she is passionate about learning languages, history and dancing.

What first sparked your interest in travel?

A. Despite living behind the Iron Curtain, I had the opportunity to travel abroad as a child. I was struck by the diversity of the countries I visited and surprised by the different customs and mentalities. I quickly realized that traveling broadens horizons and encourages continuous learning and development. Thanks to my knowledge of English, right after my university graduation, I got the chance to work for a U.K. travel agency. It was to be a summer adventure and it continues to this day. Traveling and sharing my knowledge with our travelers has become a great part of my life.

What attracted you to AHI Travel?

A. The best things often happen by accident. A friend told me about interviews for a position in Kraków for AHI Travel on their Alumni Campus Abroad programs. I went to the interview, was selected and have been with AHI for 18 years!

What is your professional philosophy?

A. Travel educates. And this is not just the usual platitude but the truth itself. Continuous development and learning about new countries and their residents has made me a person who is open to people and their needs, patient and satisfied with my professional life.



Tell us about challenges and successes.

A. There have been many over the 27 years of my career. Challenges were everywhere in tourism in the 1990s — problems with crossing borders, bureaucracy and service levels. All of these things were somehow managed in the end. Thanks to such preparation, I believe that there is no situation without a way out. Success for me is hearing from my guests that my work and knowledge made our tour together unique and rewarding.

Can you share some inspiring moments?

A. For me, the most important thing is the atmosphere of the place I visit. It does not have to be the largest cathedral or the most visited museum in Europe, but these are important and our programs never miss such places. My great pleasures include getting to know small charming towns on our cruises, meeting locals, drinking coffee in a Lisbon cafe and sampling traditional delicacies at holiday markets. Our programs often offer places off the typical tourist track and this gives travelers a chance to really get to know a country. It's not only the culture that counts, but also the food, good wine or coffee. I cannot forget about the experts who often accompany our programs. Thanks to their lectures and knowledge, our programs become a well of fascinating knowledge and adventure.

"Thank you all for the wonderful trip to Chile and Patagonia. Torres del Paine is one of the most wondrous places that I have ever seen and Emiliano Rio is a treasure. His quick actions made the trip seamless. Victor, Christian and Lissette were outstanding local guides who had infinite knowledge and love for their lands. ... Again AHI is so fortunate to have such brilliant guides and travel managers."

Jane | Chilean Wonders

UCLA Faculty Lecturers

UCLA faculty are at the forefront of their fields, and leading you on your journey of discovery.



Ali Behdad | English and Comparative Literature

Ali Behdad is Professor of English and Comparative Literature, and John Charles Hillis Endowed Chair in Literature at UCLA. He is currently serving as the Director of the Center for Near Eastern Studies. He has also served as the Chair of English Department (2010-2016) and the Chair of Comparative Literature Department (2005-2010). He has published widely on travel literature, photography of the Middle East, and Orientalism. His books include *Belated Travelers* (Duke U. Press, 1994), *A Forgetful Nation* (Duke U. Press, 2005), and *Camera Orientalis* (U. of Chicago Press, 2016).

Ali will accompany the Sept. 19-27, 2024, Andalusia in a Parador (See page 34)



Dr. Susan Kresin | Slavic, East European and Eurasian Languages

Dr. Susan Kresin has been working in the Department of Slavic, East European and Eurasian Languages since 1996. She teaches Czech, Russian, courses on Slavic linguistics, and courses on Central and Eastern European culture that integrate film, literature, music and news media to bridge historical legacies with current perspectives. Her publications include edited collections of articles on Czech culture and on heritage-language speakers, a textbook of Czech, and articles on language pedagogy, comparative linguistics, and corpus-based linguistics. Her current focus of integration in language and area studies courses is media literacy.

Susan will accompany the Sept. 3-12, 2024, Grand Cities of Central Europe (See page 24)



Glen MacDonald | Environment and Sustainability

UCLA Distinguished Professor Glen MacDonald has travelled the globe uncovering evidence of climate change and its impacts on the environment and on human societies. He uses a variety of research techniques that allow him to study climate change, and the history of the Earth's environments and people as it happens today and back thousands of years into the past. Glen will share with you how geography and past climate change have shaped the landscapes of the Rhine region and influenced the histories of its peoples and places. He will also consider how current climatic changes are impacting the 21st century. Along the way Glen will share some of the adventures he has experienced during his many scientific expeditions.

Glen will accompany the Aug. 20-28, 2024, Cruise the Rhine and Moselle Rivers (See page 40)

"We love UCLA Alumni Travel. Each experience is unique and the addition of a UCLA lecturer is always a treat. Not only for the lectures, but the day to day learning which goes on talking to a UCLA professor on site."

– Dan '67, MBA '69 & Chris '67 Wolfus



UCLA travelers, Singapore, Thailand & Angkor Wat



Kathryn Norberg | History

Kathryn Norberg has taught in the UCLA Department of History for 32 years. She is a historian of Europe, specializing in French history before 1800. She is the author or editor of six books and many articles dealing with topics as diverse as the history of charity, French peasant communities, national debt crises, women during the French Revolution, eighteenth-century furniture and clothing in fashion prints. A past president of the Western Society for French history, she has taught courses on prehistory, late medieval France and royal courts. She has traveled widely in provincial France, researching projects in more than 20 French cities and Montreal, Canada. She also works in women's and gender history and twice served as Acting Chair of the UCLA Gender Studies Department. Recent projects have given Norberg a passion for military history and material culture, especially history of architecture, clothing and food.

Kate will accompany the June 15-23, 2024, Normandy (See page 22)

UCLA travelers at Omaha Beach, Normandy, France



Teo Ruiz | History

Teofilo Ruiz received his doctorate from Princeton University and has taught at many universities, including the University of Michigan and Princeton. He served as UCLA History Department chair (2002-2005) and chair of the Department of Spanish and Portuguese (2008-2009). A medievalist and early modern historian, Ruiz was selected by the Carnegie Foundation as one of the four Outstanding Teachers of the Year in 1994. The author of 14 books, he received the prestigious 2007 Guggenheim Fellowship and the Distinguished Teacher Award at UCLA. In 2012, Ruiz was selected as the Senior Research Lecturer at UCLA and received the National Humanities Medal from President Obama. With 18 past tours, Professor Ruiz is the most popular and beloved lecturer traveling with UCLA Alumni Travel.

Teo will accompany the May 18 – June 1, 2024, Grand Danube Passage (See page 44)



Michael Shin | Geography

Professor Michael Shin is a faculty member in the UCLA Department of Geography who specializes in contemporary Italian society, politics and culture. Since joining UCLA in 2001, Michael has published several articles and two books on political change in Italy, the rise of populism in Italy, Europe and the US, and Italy's infamous leader, Silvio Berlusconi. His research has been supported by the U.S. National Science Foundation, University of California Office of the President, and UCLA Faculty Senate. Michael is also the faculty director of the UCLA Geospatial initiative, the mission of which is to promote the use of digital mapping technologies in teaching and research. Fluent in Italian, he travels to Italy frequently, and has local knowledge and expertise across Tuscany.

Michael will accompany the Sept. 10-19, 2024, Tuscany & Emilia-Romagna (See page 32)





AHI is committed to you

Our passion for authentic, responsible and life-changing travel experiences defines every program.

AHI Travel, a creative travel company, is recognized around the world for deluxe, personalized group travel programs. Travel industry pioneers Richard and Arlene Small founded the company in 1962, when they launched the first alumni travel programs at universities across the U.S. Soon after, they introduced AHI in Canada. They quickly earned an outstanding reputation for quality, service and value, which we continue to deliver today to alumni and individual travelers alike.

Personal involvement shapes every aspect of our tours. Long before we finalize a program, our team of experienced travel experts stay in the hotels, eat in the restaurants and visit every site.

We detail the things that matter most to travelers — for example, the number of cathedral steps you must climb or restaurants with the best food and views!

Our aim is to please you, period. By consistently meeting travelers' high expectations over the decades, we appeal to educated, cultured and experienced travelers — people like you. Many clients have been so pleased with our programs that they boast of taking 15, 20, even 30 trips with us!

We know you have many travel options and probably just as many questions. So call one of our AHI Travel experts at 800.323.7373. We look forward to helping you plan your trip.



A World of Discovery

The story of travel involves more than a ticket and a passport. It should weave together discovery, education and humanity, the best elements of any compelling tale. Your personal travel story begins with our commitment to delivering authentic experiences with local people.

"This trip was a wonderful introduction to Cuba, offering experiences the solo traveler is not likely to encounter.

I was very happy with the selection and variety of offerings... Osmin, Melissa and Carlos were wonderful and took good care of us! I learned so much and fell in love with Cuba and its people."

Mary | Cuba

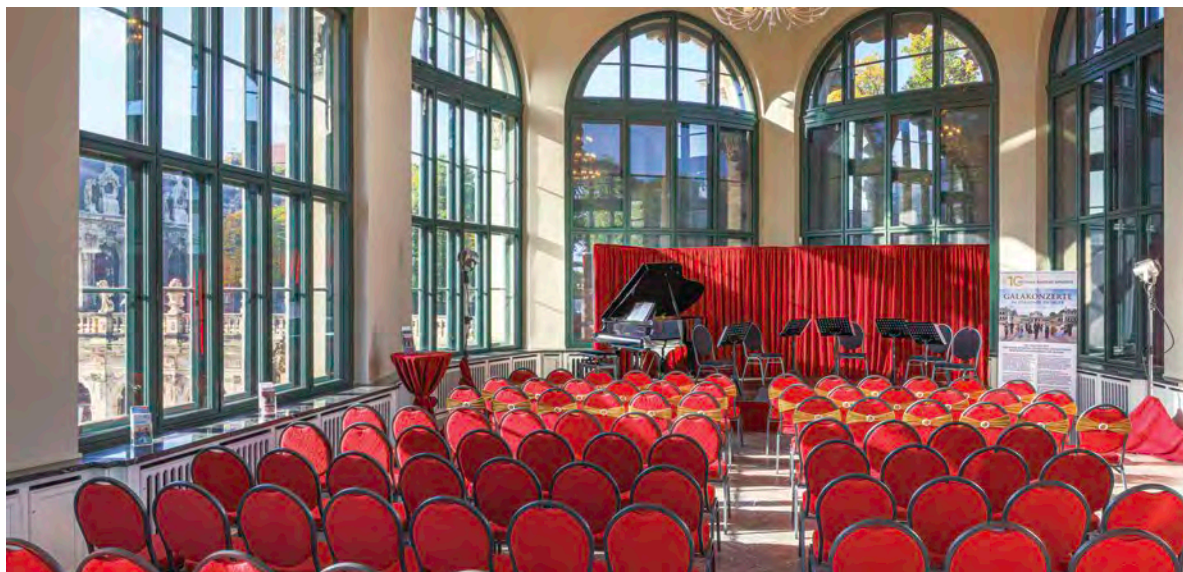

AHI Connects

From intimate dinners to behind-the-scenes visits to hands-on lessons, our team curates unique events that instill a deeper appreciation for your destination. Watch in delight as talented dogs herd sheep at a family farm in Connemara, indulge in the heavenly flavors of Parmesan cheese and balsamic vinegar in Italy or learn to make rice noodles with a local family in Cambodia. Come away with memorable, immersive experiences that also support the communities we visit!

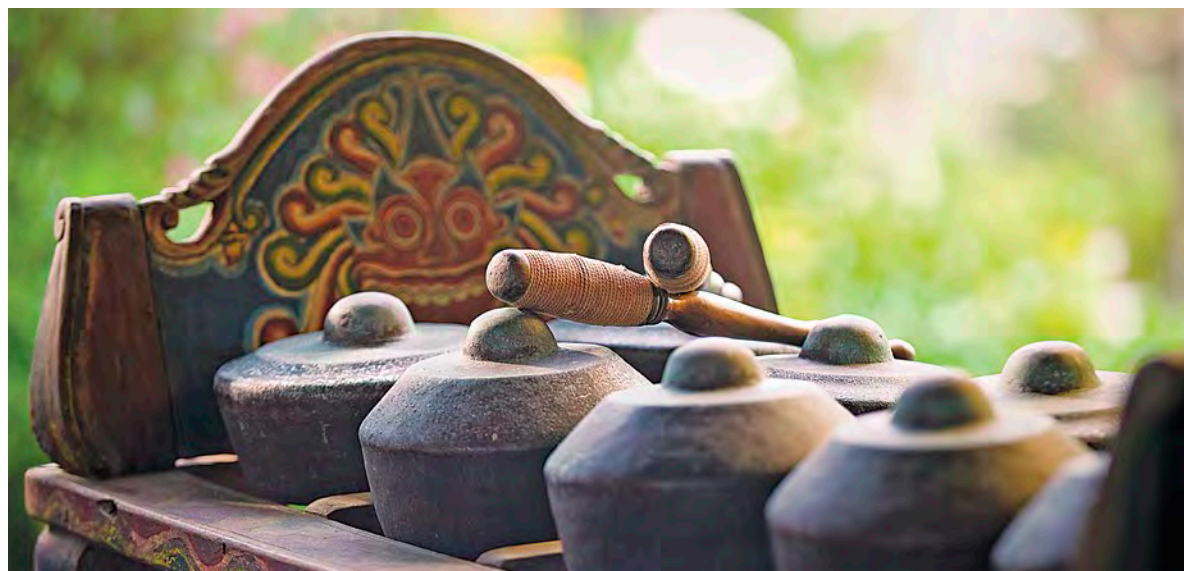



Accommodations

We personally select hotels and ships for quality, location, value and character.

For more than 60 years, we've traveled the world to evaluate hundreds of hotels for our programs. As travelers ourselves, we value high-quality, ideally located accommodations imbued with local charm and style. Our meticulous selection process promises that you'll return each evening to a well-appointed room with the comforts and little extras you crave.

Many of the properties offer thoughtful amenities, such as room service, restaurants, a salon and fitness facilities and a pool. When you're on the move during our programs, your comfort is paramount. Across land or water, we select the finest river cruisers and luxury trains for the most pleasurable experience.

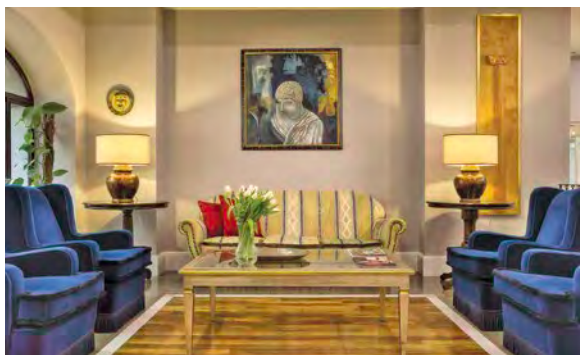

Sina Maria Luigia, Parma, Italy

Where you lay your head during your journey may not define the trip, but it certainly completes a wonderful travel experience.

Quality accommodations are a crucial aspect of our programs.



Above: Hilton Dresden, Germany | Above right: Sofitel Angkor Phokeethra Golf & Spa Resort, Siem Reap, Cambodia

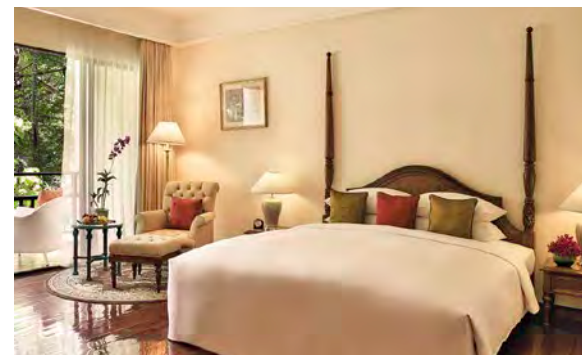

Hand-picked Hotels

- ▶ **Luxury hotels** offer the ultimate in comfort and service. Marvel at the singular attention to detail and sumptuously appointed rooms in sleek, modern hotels like The Peninsula Bangkok and the Shangri-La Hotel, Singapore.
- ▶ **Deluxe hotels** range from legendary establishments, such as the Belmond Mount Nelson Hotel in Cape Town to Kapama River Lodge, an upscale safari lodge. Historic architecture, contemporary design and extensive amenities distinguish these hotels.
- ▶ **First-class hotels**, often a distinctive boutique property or a welcoming family-owned hotel, offer satisfying comforts at the end of an exciting day. Watch a sunset from the Hotel La Palma or sip a glass of Chianti on the terrace of your Tuscan villa.



The Lodge at Castle Leslie Estate, Glaslough, Ireland



Complimentary bikes aboard MS Amadeus fleet



Enjoy Puerto Varas Hotel, Puerto Varas, Chile



MS Amadeus Diamond



Rovos Rail



Above: Villa Marsili, Cortona, Italy

Select Ships & Trains

- ▶ **River ships**, built specifically for river journeys, bring you closer to both remote villages and grand cities for intimate views of local life. From gracious service and well-appointed cabins to gourmet cuisine and onboard cultural activities, savor the unique experience of your floating hotel.
- ▶ **Elegant trains** transport you back to a golden age when the way you traveled was just as significant as the destination. Wind through the heartland in vintage train cars, impeccably restored to their glory days, and relish the sweeping views. Indulge in afternoon tea service or cocktails in the observation car.



AHI Programs

A rich tradition of innovative land and cruise programs

Knowing that educated travelers are looking for a variety of destinations, we offer intriguing adventures across the globe.

“Overall, it was a fabulous trip and we appreciate all of AHI’s knowledge and expertise in the travel industry (and local guides’ knowledge of the areas). The AHI personnel were great and they are such a delight to be with—perhaps that is what sets AHI apart—its people. Thanks a million for an unforgettable experience.”

Renee and Joe | Dutch Waterways

LAND JOURNEYS

We take you to captivating, far-flung corners of the world — from cosmopolitan Cape Town and the Cliffs of Moher to Israel’s inspiring landmarks and northern Norway above the Arctic Circle. Travel with us as we traverse golden African plains on a luxury train ride, experience Bali, Singapore, Thailand and Angkor Wat or explore old Dubai and its colorful souks. You might also enjoy lingering in unique districts during stays in Paris and Havana, or heading out to explore Alaska’s vast wilderness and Mexico’s Yucatán Peninsula.

Our specialized travel brands:

Alumni Campus Abroad® | Enhance your appreciation of your destination through exclusive educational content. Local lecturers provide a broader context for what you will experience and enlighten you with new perspectives.

Art, Culture & People | Become more familiar with the world’s greatest cities and examine the personalities of diverse neighborhoods on these in-depth explorations.



Catering to your preferences and needs:

Small Group | You’ll travel with an intimate group, limited to 28 guests, sized just right for a more individual experience, and filled with camaraderie.

Active Travel | Designed for people who are in good health and can participate in a demanding daily schedule of physical activities. Itineraries may feature full days of ongoing activities. Depending upon the excursion, more leisurely alternatives may be available.

Solo Travelers | Because we value our solo travelers, many of our trips are specially priced with no single supplement.

Multigenerational Adventure | Share your love for travel with the young adventurers in your life on a family-oriented river cruise, featuring expertly designed youth programming.

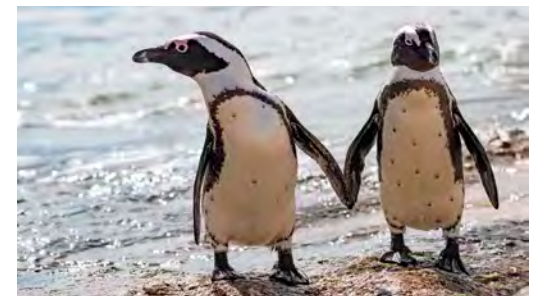

AHI Sustainability Promise

We place great emphasis on sustainable tourism, cultural preservation and economic sustainability.

We strive to make a positive, purposeful impact in the communities we visit, whenever possible. This commitment to sustainability extends to environmental, social and economic platforms.

Our Sustainability Promise outlines our commitment to preserving the environment, supporting local communities and giving back to the places we travel.

► **Environmental Impact** | Thoughtful choices to minimize our environmental footprint: eco-friendly transportation, guided walks in lieu of bus tours and less plastic and paper waste.

► **Social Impact** | Ongoing initiatives to support local businesses that employ and benefit residents. Curating meaningful experiences by staying in intimately sized locales instead of cities affected by overtourism.

► **Economic Impact** | Community-based tourism using expert local guides and lecturers, plus program scheduling during quieter, “shoulder seasons.”

RIVER & COASTAL JOURNEYS

Experience multifaceted cultures and unforgettable vistas on the world’s illustrious waterways. A pioneer in river cruising, we proudly offer customized itineraries on exclusively chartered ships in partnership with the best cruise lines. Simply unpack once to float along the scenic Main, Seine, Rhine and Moselle rivers, or enjoy a combination of river and land experiences. You may sail on the Douro River and explore Lisbon, glide along the Nile and marvel at Giza’s astounding pyramids or cruise the Amazon Basin and meander amid lofty Machu Picchu.

Your Individual Experience

Free time means something different to every traveler. You may prefer to linger in a cozy café or stay on the go. That’s why we design itineraries that allow you to craft an individual travel experience.

🌟 **PYJ | Personalize Your Journey | Included**

With our Personalize Your Journey program, AHI travelers can match a range of excursions to their interests and activity levels. From culinary tours to cycling adventures, there’s bound to be an adventure perfect for you.

🕒 **Electives | At an additional cost**

For some travelers, a deeper dive into the locations we visit can be the difference between a great trip and an extraordinary one. Our electives give you the option for more guided exploration.

Free Time

We know that unstructured time away from the group can be both relaxing and restorative. That’s why we’ve set aside some free time for you to relax, shop or explore.

Check out our itineraries for more details. We’ve done the legwork. Now the choice is yours.



A Note About Activity Levels

We have rated all of our excursions with activity levels to help you assess the physical expectations of our programs. Depending on the excursion, more leisurely alternatives may be available.

To make the best personal choice, please evaluate each excursion’s rating and your ability to meet the tour’s physical demands.

Please note that excursions on our programs require walking on cobblestones, unpaved paths and/or uneven surfaces; and getting on/off motor coaches, boats and/or trains.

Mild | Walk under 1 mile on mainly flat terrain; navigate under 50 stairs; stand under 1 hour

Moderate | Walk 1-3 miles on flat/uneven terrain; navigate 50-100 stairs; stand 1-2 hours

Active | Walk 2+ miles on flat/uneven terrain, including up and down inclines; navigate 100+ stairs; stand 3+ hours

Please call or visit our website to review the itinerary for full details about activity levels on AHI programs.



Journey to Southern Africa

Luxury Safaris, Rovos Rail & Cape Town

Inspiring Moments

- ▶ Experience the thrill of safari and marvel at incredible wildlife in **South Africa, Botswana and Zimbabwe.**
- ▶ Delight in the awe-inspiring power and grand cascades of **Victoria Falls.**
- ▶ Surround yourself in classic luxury and stirring scenery aboard **Rovos Rail.**
- ▶ Walk in the historic footsteps of Nelson Mandela on **Robben Island.**
- ▶ Meet the young people involved in projects at a **Soweto youth center.**
- ▶ Immerse yourself in the easygoing lifestyle of **Cape Town**, South Africa's oldest city.
- ▶ Experience three **UNESCO World Heritage sites.**

ACTIVE TRAVEL

Excursions on this program require:

- ▶ walking on unpaved paths and/or uneven surfaces
- ▶ getting on/off motor coaches, boats and/or trains
- ▶ walking through train corridors whether the train is in motion or stopped
- ▶ climbing in and out of safari vehicles

EXTEND YOUR STAY

Cape Town | 2 Nights | Pre-Trip

{See page 52 for details.}



Lion

Encounter an extraordinary land of contrasts, from exotic wildlife to vivacious Cape Town, thundering Victoria Falls to legendary wildlife reserves and welcoming communities to lauded landmarks. Trace a compelling route to Robben Island and fascinating towns that hold powerful history lessons. With expert guides leading the way, discover the density and diversity of animals in southern Africa's most incredible safari destinations. Plus, journey through grassy plains on a bespoke train journey aboard the elegant Rovos Rail. The people and wild nature of this wondrous destination are waiting for you!

Day-by-Day Itinerary

Days 1 & 2 | In Transit

Depart for Cape Town, South Africa. 

Day 3 | Cape Town, South Africa

Upon arrival, transfer  to your hotel. The Belmond Mount Nelson Hotel is a Cape Town landmark located across the street from the Company's Garden. Later, join us for a Welcome Reception.

Day 4 | Cape Town

Cape Peninsula. Your adventure begins! Set out to discover the region's alabaster beaches and sleepy fishing villages. Take a scenic drive to Cape Peninsula, passing the buttresses of the Twelve Apostles. At Boulders Beach, see a colony of adorable African penguins, the only penguins found on the continent. Enjoy the flavors of local cuisine during lunch.

Enrichment: South African History.

Day 5 | Robben Island | Cape Town

Cape Town Highlights. Hop on a ferry for a ride to Robben Island and tour the jail where Nelson Mandela was incarcerated. Your guide, a former prisoner of Robben Island, offers first-hand insight. After, discover the many highlights of South Africa's Mother City. Drive through the Company's Garden district, see the Castle of Good Hope and stroll along a bustling harbor.

Free Time: Spend the afternoon at leisure.

Day 6 | Victoria Falls, Zimbabwe

This morning, fly to Victoria Falls, Zimbabwe. Upon arrival, check in to the Victoria Falls Hotel.

Free Time: Enjoy leisure time to settle in the hotel.

Victoria Falls. Feel the cool mist as you revel in the planet's largest curtain of water. Twice the height of Niagara Falls, mighty Victoria Falls casts a veil of spray that can be seen up to 50 miles away!

Gather for a group dinner tonight.

Day 7 | Chobe National Park, Botswana

Safari: Chobe is a spectacular destination for bird-watchers, and the Chobe River gives life to the many animals, birds and reptiles that call the park home. Watch elephants frolicking in the water, hippos swimming and birds swooping down to catch fish.

Day 8 | Victoria Falls, Zimbabwe

This afternoon, embark Rovos Rail at Victoria Falls Station and begin your luxurious train journey.

The train overnights at Kennedy Siding.

Day 9 | Zimbabwe | Hwange National Park

Rise early for a safari at Hwange National Park.

Safari: After disembarking in Kennedy Siding, go on a game drive at The Hide, a private concession in Hwange National Park. This park, known for its natural beauty, is home to more than 100 mammal and 400 bird species. Visit one of the most popular watering holes to see some of the four-legged residents!

Board the train and travel along one of Africa's longest stretches of straight railway line.

Day 10 | South Africa

Enjoy a full day of traveling through beautiful country. Pass Bela-Bela, the hot springs resort once known as Warmbaths. The train overnights at Pyramid.

Day 11 | Pretoria | Johannesburg

Disembark in Pretoria and transfer to Johannesburg.

AHI Connects: Soweto. Visit the townships of Soweto, and drive by the homes of Nelson Mandela and Archbishop Desmond Tutu. In Kliptown, learn about a youth program that offers tutoring and options to play sports and participate in the arts. Meet some of the youth and enjoy a performance by the children. Check in to 54 on Bath in Johannesburg.

Day 12 | Hoedspruit | Kapama Private Game Reserve

Fly to Hoedspruit. Upon arrival, transfer to the stunning Kapama Private Game Reserve.

Safari: Meet your ranger and tracker, a hard-working team that will accompany you on each game drive. Climb aboard your safari vehicle and get the lay of the African bushveld during your first game drive in Kapama Private Game Reserve. The quest begins as you try to spot the majestic Big Five and enjoy encounters with Africa's untamed wildlife!

Day 13 | Kapama Private Game Reserve

Each morning begins with a wake-up call at dawn. Meet on the deck and climb into your safari vehicle.

Safari: It may seem quiet as the sun starts its journey across the sky, but there is plenty of animal activity. Many animals are just waking up and preparing to search for breakfast. Others are winding down after a night on the prowl and looking for a place to sleep. As you journey through the veld ecosystem, see how many of the Big Five you can spot today. Also keep watch for birds, reptiles and other critters!

Free Time: Spend the rest of the morning at your leisure. Perhaps visit the spa or relax with a book.

Enrichment: The Animals of Kapama.

Safari: Get a different perspective of the park's wildlife as you see diurnal animals settling down for the evening and nocturnal animals beginning theirs.

Africa's sunsets are unsurpassed! Toast to the day with a sundowner, a drink served at sunset.



Day 14 | Kapama Private Game Reserve

Safari: Every game drive is a unique experience forged by the time of day, the weather and the locale. Your tracker and ranger are experts in finding magnificent creatures in the wild. They know the thickets where giraffes nibble at the treetops, the open veld where zebra graze and much more. Feel free to ask your guides questions. They are eager to share their passion!

Free Time: Spend a leisurely morning at the lodge.

Safari: Your ranger and tracker are knowledgeable about the wildlife and plants in the park. Today, you may scout out popular watering holes, where four-legged and feathered residents gather.

Celebrate your journey at a festive Farewell Dinner, a sumptuous meal seasoned with tales of your wild animal sightings and other adventures.

Day 15 | In Transit

All passengers depart for Hoedspruit Airport, where the Land Program ends. AHI FlexAir passengers board their flight to Johannesburg.

Day 16 | In Transit

Arrive in your gateway city.

Included Features

Accommodations {with baggage handling}

– **3 nights** in Cape Town, South Africa, at the Belmond Mount Nelson Hotel.

– **2 nights** in Victoria Falls, Zimbabwe, at The Victoria Falls Hotel.

– **3 nights** aboard Rovos Rail.

– **1 night** in Johannesburg at 54 on Bath.

– **3 nights** in Kapama Private Game Reserve at the Kapama River Lodge.

Transfers {with baggage handling}

– All transfers in the Land Program: flights, train journey and deluxe motor coaches.

Extensive Meal Program

– 12 breakfasts, 8 lunches and 7 dinners, including a Farewell Dinner; tea or coffee with all meals, plus wine with dinner.

Your One-of-a-Kind Journey

– **Visit 3 countries** during this program.

– **Small group:** Sized just right at 28 guests.

– **AHI Travel Assurance** plan covers Accident and Sickness Medical Expense, Trip Delay and Emergency Evacuation for U.S. residents.

– **Enrichment by expert speakers** enhances your insight into the region.

– **Engaging excursions** showcase the local culture, heritage and history.

– **Electives** and free time to pursue your individual interests.

– **AHI Sustainability Promise:** We strive to make a positive impact wherever we travel.

– **AHI Connects:** Local immersion.

– Welcome Reception to mingle with fellow travelers.

– A personal VOX headset to hear your English-speaking guide clearly.

– Tipping of Cape Town and Soweto excursion guides and drivers.



2024 Departures & Pricing

March 17 – April 1, 2024

Full Pullman Price **\$8,745**

Special Savings **\$250**

Special Pullman Price \$8,495*

*Special price available for a limited time. Call for details.

VAT is an additional \$495 per person.

The Deluxe category is an additional \$1,500 per person.

All prices quoted are in USD, per person, based on double occupancy and do not include air transportation costs (unless otherwise stated).

Single prices are available upon request (limited availability).

Program-specific terms and conditions are available at <https://ucla.ahitravel.com/destinations/1831A?schoold=170>. You can also request a copy from our travel experts.

Note: Itinerary sequence and/or scheduled events may change. Walking is required on many excursions.

Flights and transfers provided for AHI FlexAir participants.

Electives available at an additional cost.



Bali, Singapore, Thailand & Angkor Wat

Inspiring Moments

- ▶ Delight in **Bali's** tropical environs, vibrant cultural scene and rich Balinese traditions.
- ▶ Cherish a quiet moment at the awe-inspiring monuments of **Angkor Wat, Ta Prohm and Angkor Thom.**
- ▶ Stroll through a beautiful floral oasis at Singapore's **Gardens by the Bay.**
- ▶ Thrill to the **glories of Southeast Asia,** a medley of energetic cities, stunning landscapes and ancient ruins.
- ▶ Sweet, savory, spicy and tart — delight your palate with the flavors of Southeast Asia's **outstanding food culture.**
- ▶ Encounter traditional Thai life while cruising along the **legendary Chao Phraya River.**
- ▶ Behold Singapore's harmonious blend of **traditional and modern lifestyles.**
- ▶ Experience three **UNESCO World Heritage sites.**



Rice field near Ubud, Bali

Join an enriching 12-night adventure to Southeast Asia, a land of stunning diversity. Begin in beautiful Bali, a treasure trove of cultural landmarks. Fly to Singapore and witness this modern city's fascinating attractions and neighborhoods. Unravel Bangkok's myriad layers found within its winding canals and opulent palaces and shrines. Venture beyond Bangkok to the early Siem capital of Ayutthaya before capping off the journey in Cambodia. Here, encounter the remarkable Angkor Wat and other ancient temples. Along the way, the region's welcoming locals share insights into their lives, cuisine and unique traditions.

Day-by-Day Itinerary

Days 1 & 2 | In Transit

Depart for Bali, Indonesia. 🌐

Cross the international date line.

Day 3 | Bali, Indonesia

Arrive in Bali and transfer 🚗 to the Belmond Puri Jimbaran. Spend time unpacking and becoming familiar with the amenities and lovely gardens at your hotel. Join us for tonight's Welcome Reception.

Day 4 | Bali

Balinese Village Exploration. Venture into the green hillsides to visit a local school. Take a tour and interact with the students and teachers. Next, visit a traditional housing complex and observe daily life. After, follow a gentle path to a rice field and gain insight into an ancient irrigation system called *subak*. Dig into a delicious lunch of Balinese dishes before surrendering your feet to a relaxing massage.

Day 5 | Bali

Ubud Culture and Holy Spring Temple. Head to Tampak Siring, a holy water temple believed to have incredible healing properties. Following lunch, travel to Ubud to tour the Agung Rai Museum of Art, which houses exhibition halls, art classes, cultural workshops and more. Learn about a music ensemble called the *gamelan*. You can remain at the museum or visit a nearby local market filled with handmade items.

Day 6 | Bali | Singapore

After a satisfying breakfast, fly to Singapore. Upon arrival, transfer and check in to the Shangri-La Hotel.

Day 7 | Singapore

Enrichment: Contemporary Singapore.

Singapore Discovery. On a panoramic tour, pass by the Marina Bay Sands resort, Merlion Park and the



mythical Merlion. Drive through the Civic District and visit the ancient Chinese Thian Hock Keng Temple.

Multicultural Singapore. Uncover Singapore's diverse cultures and history this afternoon. Drive through Kampong Glam, a Malay enclave that originated as a fishing village. Then explore Chinatown and Little India's vibrant flower and spice market.

Day 8 | Singapore

Peranakan Heritage. Engage with a Peranakan family while learning to make traditional Chinese dumplings. Try a tasting of this authentic dish that is often made with pork, mushrooms and tangy spices. Continue to a local home to learn about traditional beadwork and embroidery, an important aspect of Peranakan heritage.

Gardens by the Bay. Delight in Singapore's landmark oasis of floral features and garden artistry. See the iconic Supertrees, made up of over 150,000 plants, plus bromeliads, orchids, ferns and climbers. Chart your own course through the Flower Dome, the world's largest glass greenhouse, and wander through the Cloud Forest, home to unique aerial walkways.

Day 9 | Singapore | Bangkok, Thailand

Continue your adventure with a flight to Bangkok. After landing, transfer to the Peninsula Bangkok.

Enrichment: Thailand's History and Culture.

Chao Phraya River Cruise. Witness Bangkok's illustrious landmarks during a scenic evening cruise aboard a converted rice barge. Enjoy drinks and dinner while gliding by the city's sparkling skyline.

Day 10 | Bangkok

Bangkok's Highlights. Wend through the lively Chao Phraya River and Thonburi canal. Marvel at the Grand Palace and Emerald Buddha Temple, followed by lunch at the prestigious Blue Elephant restaurant.

Free Time: Craft your own path through Bangkok.

Elective | Sala Rim Naam. Immerse yourself in Thai culture during a dance show and dinner.

Day 11 | Ayutthaya

Ancient Ayutthaya. Visit the Bang Pa-In Palace, a summer residence for Thailand's kings. In the ancient capital of Ayutthaya, view brick ruins, lion guardian statues, Buddha figures and other artifacts. While cruising back to Bangkok, enjoy panoramic views and a lunch of authentic cuisine.

Day 12 | Bangkok | Siem Reap, Cambodia

Begin the day with a quick flight to Siem Reap,



Cambodia. Upon arrival, transfer to the Sofitel Angkor Phokeethra Golf and Spa Resort.

Siem Reap. Encounter the quaint provincial capital aboard a tuk-tuk, a typical mode of transportation. Visit an art and dance center to see local talent.

Enrichment: The Temples of Angkor.

Day 13 | Siem Reap

Angkor Wat. Thrill to the crown jewel of the Angkor Archaeological Park. Duck through stone-structured archways, witness extensive galleries of inspiring carvings and spy saffron-robed monks. You'll be immersed in a world long forgotten!

AHI Connects: Local Cuisine. Uncover tasty cuisine with a local family while making rice noodles.

Free Time: Spend time crafting your own path.

Cambodian Circus. Delight in a show featuring dances, acrobatics and stories of Khmer culture.

Day 14 | Siem Reap

Angkor Thom, Thommanon and Ta Prohm. At the walled city of Angkor Thom, see the imposing Bayon temple. Continue to the jungle-clad Ta Prohm, hidden amid twisting trees, and visit the recently restored Thommanon temple with its exquisite carvings. Gather for a Farewell Dinner and an exciting event featuring Khmer classical dance and music.

Day 15 | In Transit

Transfer to the Siem Reap airport for the return flight to your gateway city.

Included Features

Accommodations {with baggage handling}

- **3 nights** in Bali, Indonesia, at the deluxe Belmond Puri Jimbaran.
- **3 nights** in Singapore at the deluxe Shangri-La Hotel, Singapore.
- **3 nights** in Bangkok, Thailand, at the deluxe Peninsula Bangkok.
- **3 nights** in Siem Reap, Cambodia, at the deluxe Sofitel Angkor Phokeethra Golf and Spa Resort.

Transfers {with baggage handling}

- Flights to Singapore, Bangkok and Siem Reap and all deluxe motor coach transfers in the Land Program.

Extensive Meal Program

- 12 breakfasts, 7 lunches and 2 dinners, including a Farewell Dinner; tea or coffee with all meals, plus wine with dinner.

Your One-of-a-Kind Journey

- **Visit 4 countries** during this program.
- **Small group:** Sized just right at 28 guests.
- **AHI Travel Assurance** plan covers Accident and Sickness Medical Expense, Trip Delay and Emergency Evacuation for U.S. residents.
- **Enrichment by expert speakers** enhances your insight into the region.
- **Engaging excursions** showcase the local culture, heritage and history.
- **Electives** and free time to pursue your individual interests.
- **AHI Sustainability Promise:** We strive to make a positive impact wherever we travel.
- **AHI Connects:** Local immersion.
- Welcome Reception to mingle with fellow travelers.
- A personal VOX headset to hear your English-speaking guide clearly.
- Tipping of guides and drivers.
- Complimentary travel mementos.

2024 Departures & Pricing

October 21 – November 5, 2024

Full Price from	\$6,645
Special Savings	\$250
Special Price from	\$6,395*

*Special price available for a limited time. Call for details. VAT & port tax supplement are an additional \$495 per person. All prices quoted are in USD, per person, based on double occupancy and do not include air transportation costs (unless otherwise stated). Single accommodations are an additional \$1,695 (limited availability). Program-specific terms and conditions are available at <https://ucla.ahitravel.com/destinations/1832A?schoolid=170>. You can also request a copy from our travel experts.

Note: Itinerary sequence and/or scheduled events may change. Walking is required on many excursions. Flights and transfers provided for AHI FlexAir participants. Electives available at an additional cost.



Finland

Arctic Magnificence

Inspiring Moments

- ▶ Watch the ethereal **Northern Lights** dance overhead from your **glass-domed cabin in northern Lapland**.
- ▶ **Drive a team of energetic huskies** on a thrilling ride across the glistening fjells.
- ▶ Revel in a **snowshoe trek through a tranquil, moonlit forest** to take in the Northern Lights and the starry sky.
- ▶ Discover intriguing facets of **Finland's three Sámi cultures**.
- ▶ Soak up the **soothing steam of a sauna** and learn why it's an essential, beloved experience for Finns.
- ▶ Travel to Estonia and delight in **Tallinn's beautiful old town, a UNESCO World Heritage site**.
- ▶ Admire the stunning mix of historic and contemporary architecture in **Helsinki**.
- ▶ Meet a Sámi family and see reindeer in the wild at a **traditional reindeer farm**.

ACTIVE TRAVEL

Excursions on this program require:

- ▶ standing and walking for up to 2 hours during dogsled ride and snowshoe hike
- ▶ walking on cobblestones, unpaved paths and/or uneven surfaces
- ▶ getting on and off motor coaches and boats
- ▶ tolerating colder temperatures during outdoor activities in the snow



Northern Lights Village

From the dazzling Northern Lights to a rejuvenating sauna, bask in outdoor adventures and cool Finnish traditions in the world's happiest country! The Finnish people savor the simple pleasures of life and find joy in their close bond with nature, valuing the sense of calmness it instills. On this fabulous, seven-night adventure, appreciate what Finnish happiness is all about as you embrace the country's majestic beauty and Nordic charm! Take in hip Helsinki's urban vibes and then explore Lapland's sparkling landscapes blanketed in snow. Strap on snowshoes, marvel at wild reindeer, and yell "Mush!" to your dogsled team!

Day-by-Day Itinerary

Day 1 | In Transit

Depart for Helsinki, Finland. 

Day 2 | Helsinki, Finland

Arrive and transfer  to Hotel U14.

Join your Travel Director for a brief stroll in the area and meet later for tonight's Welcome Reception and Dinner.

Day 3 | Helsinki

Helsinki Tour. On a scenic tour, discover the striking architecture of this dynamic city founded in 1550. Visit several gems along your route, including Tuomiokirkko, the green-domed, Neoclassical cathedral built in 1852. Check out the sleek, light-filled Oodi Library, popular with Finns since it opened in 2018, and TempPELLIAUKION Church, a subterranean house of worship.

Free Time: Choose a nice spot for lunch on your own.

Enrichment: Finnish Sauna Culture. Relaxing in a sauna is a vital part of the Finnish lifestyle, a cherished ritual enjoyed alone or with family and friends. A local expert discusses the history and traditions of this quintessentially Finnish experience.

Löyly Sauna Experience. With your fresh insights, it's time to do as the Finns do! At Löyly Sauna, try different styles of saunas, and if you're game, cool off with a bracing dip in the Baltic Sea!

Free Time: Get a wonderful taste of Helsinki's vibrant and inventive food scene tonight.

Day 4 | Tallinn, Estonia | Helsinki, Finland

After breakfast, travel by ferry across the Gulf of Finland on a two-hour journey to Tallinn, Estonia.

Tallinn Walking Tour. Founded in the 12th century, Tallinn boasts an enchanting, medieval old town. Its delightful Gothic and baroque churches, elegant spires and red-tile roofed buildings imbue this Baltic gem with a special romance. On a guided walk through this UNESCO World Heritage site, see top landmarks while



Viru Gate, Old Town, Tallinn, Estonia



•**Snowmobile Safari.** Zip across powdery snow on a breathtaking ride. Your guide will provide safety training and accompany you. Pause for great photos and a warm drink. *(Very Active)*

Free Time: Perhaps unwind in the sauna or enjoy the free cross-country ski and snowshoe rentals.

🌍**AHI Connects: Happiest People in the World.** Finland routinely ranks as one of the happiest nations. Discover the reasons behind the Finns' strong sense of well-being from a local expert. Then, follow her into the forest to learn how to bask in the splendor of the natural world in true Finnish fashion.

Join your fellow travelers for dinner in the restaurant.

Day 8 | Saariselkä

Free Time: Pursue your own passions in the great outdoors of Lapland! The Village offers many optional experiences (at an additional cost), such as snowmobile tours, cross-country skiing lessons or ice fishing.

Celebrate together at a Farewell Reception and Dinner.

Day 9 | Ivalo | Helsinki | In Transit

After breakfast, transfer to the Ivalo airport and fly to Helsinki. Connect in Helsinki to your international flights home.

Included Features

Accommodations {with baggage handling}

- **3 nights** in Helsinki, Finland, at the first-class Hotel U14.
- **4 nights** in Saariselkä at the first-class Northern Lights Village.



Transfers {with baggage handling}

- All transfers in the Land Program: flights, ferry and deluxe motor coaches.

Extensive Meal Program

- 7 breakfasts, 1 lunch and 6 dinners, including Welcome and Farewell Dinners; tea or coffee with all meals, plus wine with dinner.

Your One-of-a-Kind Journey

- **Small group:** Sized just right at 24 guests.
- **AHI Travel Assurance** plan covers Accident and Sickness Medical Expense, Trip Delay and Emergency Evacuation for U.S. residents.
- **Enrichment by expert speakers** enhances your insight into the region.
- **Engaging excursions** showcase the local culture, heritage and history.
- **PYJ | Personalize Your Journey**
A choice of excursions in selected locales.
- **AHI Sustainability Promise:** We strive to make a positive impact wherever we travel.
- **AHI Connects:** Local immersion.
- Welcome and Farewell Receptions.
- A personal VOX headset to hear your English-speaking guide clearly.
- Tipping of guides and drivers.



2024 Departures & Pricing

April 7-15, 2024

Full Price from	\$4,745
Special Savings	\$250
Special Price from	\$4,495*

*Special price available for a limited time. Call for details. VAT & port tax supplement are an additional \$395 per person. All prices quoted are in USD, per person, based on double occupancy and do not include air transportation costs (unless otherwise stated). Single accommodations are an additional \$1,095 (limited availability).

Program-specific terms and conditions are available at <https://ucla.ahitravel.com/destinations/1801A?schoolid=170>. You can also request a copy from our travel experts.

Note: Itinerary sequence and/or scheduled events may change. Walking is required on many excursions.

Flights ✈️ and transfers 🔄 provided for AHI FlexAir participants.

exploring along the picturesque cobblestone lanes.

Free Time: Enjoy lunch and see more of Tallinn.

Rejoin the group and embark the ferry for Helsinki. During your journey, dinner will be served on board.

Day 5 | Ivalo | Saariselkä

This morning, check out of the hotel and depart for the airport. Fly to Ivalo Airport in Lapland and transfer to Saariselkä. Check in to the Northern Lights Village. Spend some time getting settled in your cozy cabin and checking out the Village's lovely surroundings.

Gather for a delicious dinner in the Village's restaurant.

Aurora Expedition. This evening, take an invigorating snowshoe hike under a moonlit sky amid the stillness of the pristine forest and fjells. Your guide will lead you over gentle slopes to special vantage points for the chance to witness the awe-inspiring Aurora Borealis, or Northern Lights. During the springtime months, an optimal time of year for viewing, this amazing natural phenomenon can be seen approximately every second night in northern Lapland, weather permitting. Savor a refreshing break by a fire, complemented by toasty beverages, snacks and tales about the Northern Lights.

Day 6 | Inari | Saariselkä

After breakfast, depart for today's excursions in Inari.

Sámi Museum Siida. View fascinating exhibits about the traditional livelihoods, handicrafts and clothing of Finland's three Sámi cultures. Explore an outdoor area with dwellings, dugouts, turf buildings and traps.

Relish a tasty, authentic Finnish lunch at the museum.

🌍**AHI Connects: Finnish Reindeer Farm.** Reindeer husbandry has been an intrinsic part of Sámi culture since the Middle Ages. At a farm owned by a Sámi family, ride through the forest to observe reindeer and chat with the reindeer herder about daily life.

Head to the Village restaurant for a satisfying dinner.

Day 7 | Saariselkä

🌍**PYJ | Choose one of the following excursions:**

•**Husky Safari.** Drive a team of eager huskies on a fast-paced journey across the fjells. You'll receive training from the guide who will lead the group. *(Very Active. Requires strong balance over two hours.)*



Normandy

Inspiring Moments

- ▶ Contemplate the extraordinary bravery of the Allied landing forces as you walk along the **beaches of Normandy**.
- ▶ Immerse yourself in **wartime history** with riveting details from expert guides.
- ▶ Explore the impact of World War II at the **Caen Memorial Museum**.
- ▶ Marvel at stunning **Mont-Saint-Michel** rising spectacularly over the tidal waters.
- ▶ Savor a wonderfully prepared lunch at a **stately, 10th-century castle**.
- ▶ Delight in the local color and delicious cuisine along **Honfleur's picturesque harbor**.
- ▶ Follow the epic story embroidered into the acclaimed **Bayeux Tapestry**.
- ▶ Sip **Calvados**, Normandy's celebrated cider brandy, on an estate.

ALUMNI CAMPUS
ABROAD®

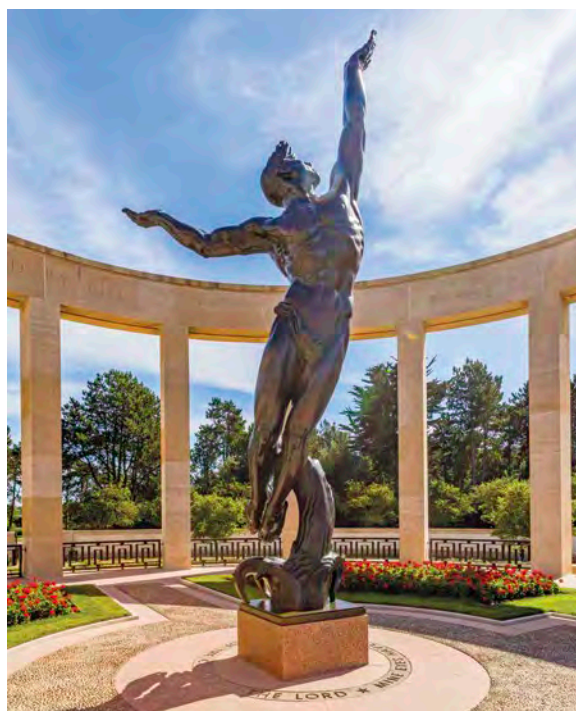

*"The Spirit of American Youth Rising from the Waves,"
Normandy American Cemetery*

From Normandy's cliff-lined coast to its breathtaking countryside, discover proud traditions, dramatic history, culinary delicacies and alluring beauty on this seven-night exploration! And as the world marks the 80th anniversary of D-Day, spend two full days visiting the D-Day beaches, the Normandy American Cemetery and other sites associated with this pivotal World War II operation. You'll also admire some of France's greatest treasures, including magnificent Mont-Saint-Michel and the finely stitched Bayeux Tapestry. Plus, look forward to a memorable lunch at a lovely castle and a Calvados tasting on a pastoral estate!

Day-by-Day Itinerary

Day 1 | In Transit

Depart for Paris, France. 🚗

Day 2 | Paris, France | Honfleur

Upon arrival, transfer 🚗 to the Mercure Honfleur Hotel. Gather for tonight's Welcome Reception and Dinner.

Day 3 | Honfleur

Historic Honfleur Walking Tour. This picture-perfect port town has captivated artists for centuries. Soak up the maritime ambience of its 17th-century harbor and stroll with your guide on the narrow side streets to see landmarks like the wooden Church of Sainte-Catherine crafted by 15th-century shipbuilders.

Free Time: Explore Honfleur on your own. Be sure to try Normandy's world-class cheeses, Camembert de Normandie, Livarot, Neufchâtel and Pont-l'Évêque, made with the rich milk of the Normande cows. Enjoy regional specialties for dinner in Honfleur.

Day 4 | Le Mont-Saint-Michel

Mont-Saint-Michel. With one glimpse of Mont-Saint-Michel's singular silhouette rising above the surrounding flat sands, you'll understand why this UNESCO World Heritage site is considered a wonder of the Western world. On a guided tour, explore this fascinating tidal island, and visit the serene abbey and church that have drawn pilgrims for centuries. If you'd like, walk on the ramparts to take in the coastal views. *(Active)*

Day 5 | Caen | Utah Beach | Sainte-Mère-Église

Le Mémorial de Caen. Expand your understanding of World War II, the D-Day landings and the Battle of Normandy at this informative, award-winning museum.

🌍 **AHI Connects: Calvados.** Normandy's apple cider brandy is among the world's finest brandies. Visit an estate that distills Calvados from the apples grown on its orchards. Learn about the process, and then savor a delectable lunch and a glass of smooth Calvados.



Utah Beach and Sainte-Mère-Église. The Normandy coastline provided the theater for Operation Overlord, one of history's largest and most complex military operations. In the very early hours of June 6, 1944, paratroopers and glider units arrived inland, tasked with sealing off German access to the amphibious assault sites. By daybreak, the second phase began as infantry and tanks came ashore on five beaches codenamed Utah, Omaha, Gold, Juno and Sword. At the Musée du Débarquement at Utah Beach, hear gripping details from your guide about how the invasion unfolded. Then, visit Sainte-Mère-Église, where U.S. paratroopers landed chaotically amid enemy fire and later secured the town's strategic crossroads.

Day 6 | Château du Bec

Château du Bec. Cross the elegant, cable-stayed Pont de Normandie that spans the Seine on your way to Château du Bec, a privately owned, 10th-century castle. Meet one of the owners and walk through the beautiful, wooded grounds. Then try flavorful, local beers and wines and indulge in a tasty buffet lunch.

Enrichment: The French Resistance. Delve into the Resistance: its origins, leaders and the heroic efforts of the French patriots who fought to liberate their country.

Free Time: Make your own dinner plans this evening.

Day 7 | Arromanches | Omaha Beach | Normandy American Cemetery | Pointe du Hoc

Enrichment: D-Day and the Battle of Normandy. Gain insights on the pivotal role that Normandy played during this crucial period of the Allied war effort.

D-Day and the Battle of Normandy. See the site of an offshore mulberry harbor in Arromanches and visit the museum there. These artificial harbors enabled the Allies to funnel enormous resources into France to wage war against Hitler. Then, walk along Omaha Beach and reflect upon the extraordinary bravery of the Allied landing forces, who valiantly advanced under devastating fire across the heavily fortified shoreline. Afterward, visit the Normandy American Cemetery in Colleville-sur-Mer, which contains the graves of



9,385 Americans who died in the invasion and ensuing battles as well as a memorial garden honoring those missing in action. Head next to Pointe du Hoc, where U.S. Rangers scaled 100-foot cliffs to destroy enemy artillery. Learn about this treacherous mission and go inside a German defensive emplacement. During today's excursion, break for lunch at a restaurant.

Day 8 | Bayeux | Honfleur

Bayeux. View the renowned Bayeux Tapestry, an embroidered masterpiece nearly 230 feet long with more than 50 scenes related to the 11th-century Norman conquest of England. Later, admire the Gothic details of Bayeux's Notre Dame Cathedral.

Free Time: Enjoy lunch on your own in Bayeux before returning to the hotel.

Tonight, celebrate your Normandy journey with your fellow travelers at a Farewell Reception and Dinner.

Day 9 | In Transit

Transfer to the airport in Paris for the return flight to your gateway city.

Included Features

Accommodations {with baggage handling}

– **7 nights** in Honfleur, France, at the first-class Mercure Honfleur Hotel.

Extensive Meal Program

– 7 breakfasts, 3 lunches and 3 dinners, including Welcome and Farewell Dinners; tea or coffee with all meals, plus wine with dinner.

Your One-of-a-Kind Journey

- **Small group:** Sized just right at 28 guests.
- **AHI Travel Assurance** plan covers Accident and Sickness Medical Expense, Trip Delay and Emergency Evacuation for U.S. residents.
- **Enrichment by expert speakers** enhances your insight into the region.
- **Engaging excursions** showcase the local culture, heritage and history.
- **AHI Sustainability Promise:** We strive to make a positive impact wherever we travel.
- **AHI Connects:** Local immersion.
- Free time to pursue your individual interests.
- Welcome and Farewell Receptions to mingle with fellow travelers.
- A personal VOX headset to hear your English-speaking guide clearly.
- Tipping of guides and drivers.
- Complimentary travel mementos.

NO SINGLE SUPPLEMENT for Solo Travelers



2024 Departures & Pricing

June 15-23, 2024

Full Price from	\$4,245
Special Savings	\$250
Special Price from	\$3,995*

*Special price available for a limited time. Call for details. VAT & port tax supplement are an additional \$295 per person. All prices quoted are in USD, per person, based on double occupancy and do not include air transportation costs (unless otherwise stated). **Single supplement waived for solo travelers!** This offer is limited, capacity-controlled and tends to sell out quickly. Program-specific terms and conditions are available at <https://ucla.ahitravel.com/destinations/1759A?schoolid=170>. You can also request a copy from our travel experts. **Note:** Itinerary sequence and/or scheduled events may change. Walking is required on many excursions. Flights and transfers provided for AHI FlexAir participants.

Above: Mont-Saint-Michel | Above right: Calvados distillery



Grand Cities of Central Europe

Berlin | Dresden | Prague

Inspiring Moments

- ▶ Delight in **three memorable musical performances** at wonderful venues.
- ▶ See poignant pieces of 20th-century history in **Berlin**, including the Berlin Wall and Brandenburg Gate.
- ▶ Admire breathtaking **Dresden**, transformed with lovingly rebuilt architecture.
- ▶ Feel the spirit of **Prague**, one of the most captivating cities in Central Europe.
- ▶ Be wowed by the outstanding art collection at the **Old Masters Picture Gallery**.
- ▶ Take in Frederick the Great's magnificent gardens and a stately palace in **Potsdam**.
- ▶ Relish the picturesque Saxon Alps on a short **cruise along the Elbe River**.
- ▶ Experience two **UNESCO World Heritage sites**.

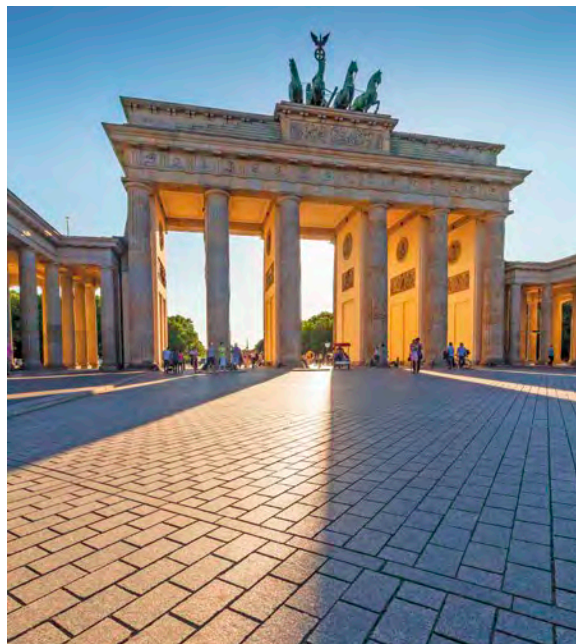

Brandenburg Gate, Berlin

Explore the celebrated cities of Berlin, Dresden and Prague, steeped in Old-World grandeur and vibrant culture, over eight nights at deluxe hotels! Revel in an enriching, music-filled journey brimming with engaging excursions, concerts at unique venues and new insights about German and Czech history. In the company of expert guides, appreciate each city's special character shaped by tumultuous times and eras of revitalization. Marvel at the last remaining piece of the Berlin Wall, Dresden's exquisite Church of Our Lady, the regal ambience of Prague Castle and much more. It's an unforgettable, inspiring experience not to be missed!

Day-by-Day Itinerary

Day 1 | In Transit

Depart for Berlin, Germany. 🌐

Day 2 | Berlin, Germany

Arrive and transfer 🚗 to the Hilton Berlin.

Tonight, gather for a Welcome Reception and Dinner.

Day 3 | Berlin

Enrichment: A Tale of Two Cities: East Berlin and West Berlin. Once divided, Berlin was reunited after the infamous Berlin Wall was torn down in 1989. An expert discusses the lasting impact in its two former sectors.

Panoramic Berlin and Berlin Wall Memorial. On a scenic tour, see top sites including Brandenburg Gate, the Federal Chancellery, the elegant Unter den Linden boulevard and the Reichstag. Then, take a guided walk to view the last preserved section of the Berlin Wall. Stop for lunch with your group during the excursion.

Free Time: Get acquainted with the city's pleasant parks, hip cafés and inviting biergartens! Your Travel Director can offer sightseeing and dining suggestions.

Day 4 | Potsdam | Berlin

Enrichment: Music in Berlin. Gain insights on the city's musical artistry and innovations from an expert.

Potsdam. Designed in 1914 in the style of an English country manor, Cecilienhof Palace famously served as the setting for the 1945 Potsdam Conference attended by President Harry S. Truman, British Prime Minister Winston Churchill and Soviet leader Joseph Stalin. Hear about its history on a guided tour. Later, stroll through the formal, terraced Sanssouci gardens, planned by Frederick the Great in 1743. Finish in Potsdam's charming Dutch Quarter with time at leisure for lunch and shopping.

Concert at Piano Salon Christophori. Join your group for top-notch classical music with a cool vibe at this wonderfully intimate and unusual locale.

ALUMNI CAMPUS
ABROAD®



Included Features

Accommodations {with baggage handling}

- **3 nights** in Berlin, Germany, at the deluxe Hilton Berlin.
- **2 nights** in Dresden at the deluxe Hilton Dresden.
- **3 nights** in Prague, Czech Republic, at the deluxe Cosmopolitan Hotel Prague.

Transfers {with baggage handling}

- Deluxe motor coach transfers during the Land Program.

Extensive Meal Program

- 8 breakfasts, 3 lunches and 3 dinners, including Welcome and Farewell Dinners; tea or coffee with all meals, plus wine with dinner.

Your One-of-a-Kind Journey

- **Small group:** Sized just right at 28 guests.
- **AHI Travel Assurance** covers Accident and Sickness Medical Expense, Trip Delay and Emergency Evacuation for U.S. residents.
- **Enrichment by expert speakers** enhances your insight into the region.
- **Engaging excursions** showcase the local culture, heritage and history.
- **AHI Sustainability Promise:** We strive to make a positive impact wherever we travel.
- Welcome and Farewell Receptions to mingle with fellow travelers.
- A personal VOX headset to hear your English-speaking guide clearly.
- Tipping of guides and drivers.
- Complimentary travel mementos.



Day 5 | Dresden

Check out of the hotel and depart for Dresden.

Dresden City and Culinary Tour. Take a fascinating guided walk in the old town, which has been faithfully reconstructed after the devastation of World War II. Visit Frauenkirche, or the Church of Our Lady, rebuilt to its original baroque splendor. Along your route, pop into local restaurants to sample tasty Saxon dishes.

Check in to the Hilton Dresden.

Free Time: Explore more of Dresden independently. You might choose to tour the Green Vault, which houses spectacular decorative objects and jewelry amassed by Saxon rulers.

Day 6 | Dresden

Old Masters Picture Gallery. View fine paintings and sculpture from the 15th to 18th centuries on a guided visit. Their impressive collection includes renowned art from the Dutch Golden Age and Italian Renaissance.

Free Time: Pursue your own interests this afternoon.

Concert at Dresden Zwinger. Look forward to an evening of classical music at the Rampart Pavilion, part of the enchanting, baroque Dresden Zwinger complex. Savor a delectable, post-performance dinner with your fellow travelers at a restaurant in the old town.

Day 7 | Prague, Czech Republic

Check out of the hotel and travel toward Prague.

Elbe River Cruise. On your way, embark on a short boat ride along the Elbe River through the stunning Saxon Alps, notable for the strikingly shaped Elbe Sandstone Mountains formed by water erosion.

Continue to Prague by motor coach, and pause for a delicious lunch during your journey.

Check in to the Cosmopolitan Hotel Prague. Regarded as one of Europe's most beautiful cities, Prague boasts a rich array of buildings, palaces, churches and bridges that reflects its evolution over eight centuries.

Enrichment: Velvet Revolution. A local expert delves into this pivotal event that led to the end of communism in Czechoslovakia and preceded the country's split into the Czech Republic and Slovakia.



Free Time: Make your own plans for dinner tonight.

Day 8 | Prague

Old Town Prague. On a guided stroll, learn about the Romanesque, Gothic, Renaissance and baroque gems in the historic center, a UNESCO World Heritage site.

Free Time: Set off on your own adventures! Perhaps check out the city's splendid spires from the acclaimed Charles Bridge, lined with statues of religious figures.

Day 9 | Prague

Prague Castle. Marvel at this vast, grand castle, the seat of Czech rulers since the ninth century. With your guide, see Castle Square, the Chapel of the Holy Cross and the old Royal Palace. Admire the St. Wenceslaus Chapel inside St. Vitus Cathedral and the 16th-century homes along Golden Lane once occupied by the castle's guards, goldsmiths and servants. *(Active)*

Concert at Lobkowicz Palace. Listen to lovely music by Bach, Beethoven and Mozart, among others, in an ornate, 17th-century hall within the castle.

Free Time: Enjoy the afternoon at leisure in Prague. Tonight, celebrate at a Farewell Reception and Dinner.

Day 10 | In Transit

Transfer to the airport for the return flight to your gateway city.

2024 Departures & Pricing

September 3-12, 2024

Full Price from	\$4,745
Special Savings	\$250
Special Price from	\$4,495*

*Special price available for a limited time. Call for details.

VAT & port tax supplement are an additional \$395 per person.

All prices quoted are in USD, per person, based on double occupancy and do not include air transportation costs (unless otherwise stated).

Single accommodations are an additional \$995 (limited availability).

Program-specific terms and conditions are available at <https://ucla.ahitravel.com/destinations/1828A?schoollid=170>. You can also request a copy from our travel experts.

Note: Itinerary sequence and/or scheduled events may change. Walking is required on many excursions.

Flights and transfers provided for AHI FlexAir participants.



Coastal Gems of the Emerald Isle

featuring the Wild Atlantic Way

Inspiring Moments

- ▶ Witness the Wild Atlantic Way's sensational beauty at **The Burren and Cliffs of Moher**, a UNESCO Global Geopark.
- ▶ Take in the towering **Slieve League** sea cliffs and the otherworldly stones of **Giant's Causeway**.
- ▶ Tap your toes to a rousing **Irish music and dance performance**.
- ▶ Taste the best of contemporary and classic Irish cuisine on a **Donegal food tour**.
- ▶ Explore Northern Ireland's walled city of **Derry-Londonderry**.
- ▶ Visit **Kylemore Abbey** and **Glenveagh Castle**, two grand, 19th-century castles.
- ▶ Watch in delight as **talented dogs herd sheep** at a family farm in Connemara.

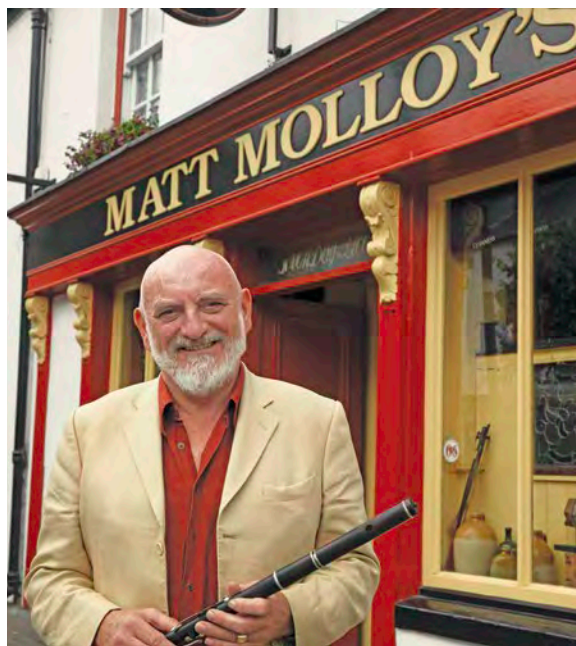

Westport

The Emerald Isle's spectacular beauty awaits you on this heartwarming, culture-filled journey that includes less explored County Donegal and Northern Ireland! Feast your eyes on the majestic Wild Atlantic Way and discover the ruggedly beautiful islands of Inishmore and Achill. Gaze across Connemara's glacier-carved landscapes, stand atop Ireland's highest sea cliffs and wonder at intriguing Giant's Causeway. You'll also feel the warm, welcoming ambience of small towns and lively cities like Galway and Derry-Londonderry. Along the way, listen to a storyteller and watch border collies corral sheep!

Day-by-Day Itinerary

Day 1 | In Transit

Depart for Shannon, Republic of Ireland. 🌐

Day 2 | Shannon, Republic of Ireland | Ennis

Transfer 🚗 to the Old Ground Hotel in Ennis.

Join your Travel Director for a short stroll around Ennis. Tonight, gather for a Welcome Reception and Dinner, capped off by music and dancing by local performers!

Day 3 | The Burren | Cliffs of Moher

Enrichment: Irish Seanchaí. Eddie Lenihan, Ireland's premier folklorist/seanchaí, tells traditional tales of folk heroes, mythology and the supernatural.

The Burren and the Cliffs of Moher. Take in these marvelous natural wonders on the Wild Atlantic Way. Expert Tony Kirby leads you on an exclusive, guided walk across the Burren's striking landscape of karstic limestone and diverse flora. After lunch at a pub, see the megalithic portal tomb, Poulnabrone. Next, admire the dramatic Cliffs of Moher, rising 700 feet above the Atlantic Ocean, and the sweeping coastal vistas.

Day 4 | Aran Islands

Aran Island of Inishmore. Ferry across Galway Bay to the largest of the Aran Islands. As you explore on a minibus, your local guide will share entertaining stories about life on this starkly beautiful island, where Gaelic is the first language. Visit a family-run business that hand-harvests edible seaweeds for a talk and tasting of this ancient food source. Afterward, see cliffside Dun Aengus, the most famous of the Aran Islands' Bronze Age forts, and pause for lunch before your return ferry.

Day 5 | Galway | Westport

Check out of the hotel and head toward Westport.

Galway. Delight in this spirited city's medieval lanes buzzing with street performers and students. Take a guided walk and find a nice spot for lunch on your own. Depart for Westport and check in to your hotel.

Below: Giant's Causeway
Right: Derry-Londonderry

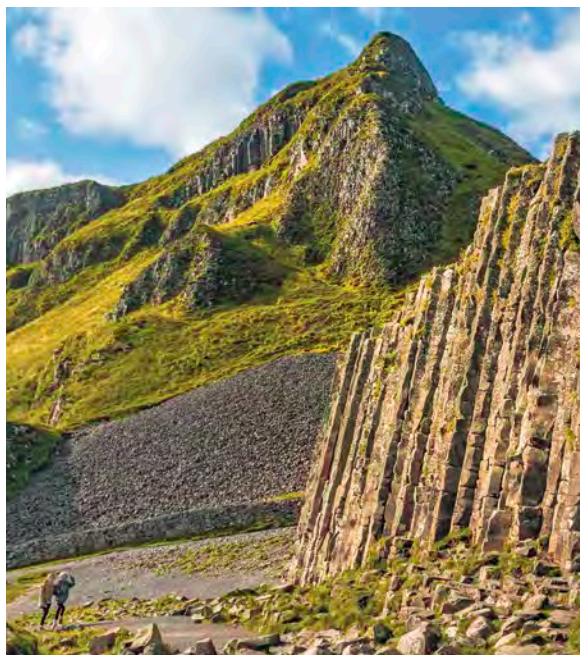

Westport Walking Tour. Get acquainted with this charming town and its elegant Georgian architecture.

Day 6 | Achill Island

Enrichment: A Vision of Ireland. A local artist and art historian reveals the history within Irish works of art.

Achill Island. Amid Achill's untamed splendor, see the Deserted Village of Slievemore dotted with the ruins of nearly 80 abandoned stone cottages. After lunch on the island, learn how to make an authentic Irish coffee.

Day 7 | Connemara

Connemara. Witness this brooding terrain of craggy mountains and windswept bogs. Stand at the base of Croagh Patrick, where St. Patrick is said to have fasted for 40 days in the fifth century, and visit the National Famine Memorial. Head next to romantic Kylemore Abbey, a 19th-century castle, for a guided tour.

AHI Connects: Glen Keen Farm. Observe border collies herding a flock on a family-owned farm and learn more about the dogs and sheep farming.

Day 8 | County Sligo | Donegal | Slieve League | Letterkenny

County Sligo. In "Yeats' Country," appreciate the stirring scenery beloved by poet William Butler Yeats, and visit his grave at Drumcliffe Cemetery.

Free Time: Enjoy lunch in the small town of Donegal.

Slieve League. Take in breathtaking views of Donegal Bay on a walk at Europe's highest accessible sea cliffs. Check in to the Castle Grove Country House.

Day 9 | Donegal

Free Time: Relish a leisurely morning at the hotel.

Donegal Food Tour. Savor the county's innovative, exciting food scene as you travel from town to town.

Day 10 | Glenveagh National Park

Glenveagh National Park. Tour stately Glenveagh Castle in this wild, remote park, followed by lunch and free time in the lush gardens.

Glebe House & Gallery. Visit the former home of a renowned artist filled with an eclectic art collection.

Leo's Tavern. Relax at this famous pub owned by



present and former members of the band Clannad, including Enya and Moya Brennan.

Day 11 | Derry-Londonderry, Northern Ireland | Giant's Causeway | Glaslough, Republic of Ireland

After breakfast, check out of the hotel.

Derry-Londonderry and Giant's Causeway. Delve into the fascinating history of vibrant Derry-Londonderry on a guided stroll and enjoy lunch. Then, journey to Giant's Causeway, a UNESCO World Heritage site. Marvel at the huge, basalt columns left behind by the giant Finn McCool or an ancient volcanic eruption.

Continue to Glaslough and check in to The Lodge at Castle Leslie Estate, set on 1,000 acres of countryside.

Day 12 | Glaslough

Free Time: Enjoy the grounds filled with sparkling lakes and ancient woods, or choose from optional activities such as spa treatments, fishing and archery.

Share in a Farewell Reception and Dinner tonight.

Day 13 | In Transit

Transfer to the airport in Dublin for the return flight to your gateway city.

Included Features

Accommodations {with baggage handling}

- **3 nights** in Ennis, County Clare, at the first-class Old Ground Hotel.
- **3 nights** in Westport, County Mayo, at the first-class Westport Plaza Hotel.
- **3 nights** in Letterkenny, County Donegal, at the first-class Castle Grove Country House.
- **2 nights** in Glaslough, County Monaghan, at The Lodge at Castle Leslie Estate, a first-class property.

Transfers {with baggage handling}

- Deluxe motor coaches during the Land Program.

Extensive Meal Program

- 11 breakfasts, 6 lunches and 5 dinners, including Welcome and Farewell Dinners; tea or coffee with all meals, plus wine with dinner.

Your One-of-a-Kind Journey

- **Small group:** Sized just right at 28 guests.
- **AHI Travel Assurance** covers Accident and Sickness Medical Expense, Trip Delay and Emergency Evacuation for U.S. residents.
- **Enrichment by expert speakers** enhances your insight into the region.
- **Engaging excursions** showcase the local culture, heritage and history.
- **AHI Sustainability Promise:** We strive to make a positive impact wherever we travel.
- **AHI Connects:** Local immersion.
- Welcome and Farewell Receptions to mingle with fellow travelers.
- A personal VOX headset to hear your English-speaking guide clearly.
- Tipping of guides and drivers.
- Complimentary travel mementos.



2024 Departures & Pricing

June 2-14, 2024

Full Price from	\$5,245
Special Savings	\$250
Special Price from	\$4,995*

*Special price available for a limited time. Call for details.
VAT & port tax supplement are an additional \$395 per person.
All prices quoted are in USD, per person, based on double occupancy and do not include air transportation costs (unless otherwise stated).
Single accommodations are an additional \$795 (limited availability).
Program-specific terms and conditions are available at <https://ucla.ahitravel.com/destinations/1834A?schoolid=170>. You can also request a copy from our travel experts.
Note: Itinerary sequence and/or scheduled events may change. Walking is required on many excursions.
Flights and transfers provided for AHI FlexAir participants.

Above right: Kylemore Abbey



The Charm of the Amalfi Coast

Inspiring Moments

- ▶ Cruise along the splendid **Amalfi Coast**, where colorful homes cling to rugged hills.
- ▶ Relax amid lemon-scented breezes in beautiful, cliffside **Sorrento**.
- ▶ Uncover remarkable history at **Pompeii and Herculaneum**, plus enjoy a visit to the Naples Archaeological Museum.
- ▶ Visit a farm for a **tour and tasting** of locally made olive oils and cheeses.
- ▶ Witness three of the world's best-preserved Greek temples at **Paestum**.
- ▶ Delight in **sensational cuisine**, including the local favorite, pizza *Napoletana*.
- ▶ Experience four **UNESCO World Heritage sites**.



Sorrento

ALUMNI CAMPUS
ABROAD®

Surrender to the sapphire beauty and enchanting atmosphere of the Amalfi Coast, where the air is fragrant with lemon zest and sweet ocean breezes. Stay in the bewitching town of Vietri sul Mare and spend sun-drenched days discovering the region's incredibly colorful palette. Encounter the whispering relics of ancient cities, listen to the sea splashing along soft shores and visit illustrious landmarks steeped in history. Embrace the incredible ambience sweeping from Amalfi to dynamic Naples to storybook Sorrento, and indulge in the authentic local flavors and unforgettable experiences awaiting you.

Day-by-Day Itinerary

Day 1 | In Transit

Depart for Naples, Italy. 🌐

Day 2 | Naples, Italy | Vietri sul Mare

Arrive in Naples, transfer 🚗 to Vietri sul Mare and check in to the Hotel Raito.

Meet your fellow travelers at tonight's Welcome Reception and Dinner.

Day 3 | Ravello | Amalfi | Positano

The Amalfi Coast. Experience the UNESCO-listed Amalfi Coast. The Italians nicknamed this shoreline "The Divine Coast" because of its scenic grandeur, amazing vertical landscape and varied architecture. Begin in Ravello, perched high on a rocky spur overlooking the sea. Ravello has intrigued and inspired writers, actors, musicians and composers alike. Visit the 13th-century Villa Rufolo, featuring a square courtyard, Arab-Norman style towers, Oriental arcades and magnificent gardens. Continue to Amalfi town and take a short orientation tour to see the piazza and Cattedrale di Sant' Andrea. Next, board a boat for a ride to Positano. During your cruise, notice the charming villages and pastel-colored villas clinging to the cliffs. Arrive in Positano where gardens climb hillsides and dramatic terraces are draped with pink bougainvillea.

Return to Vietri sul Mare and gather for a delicious dinner of regional cuisine.

Day 4 | Paestum

Paestum. Explore these ancient grounds, a UNESCO World Heritage site. This Greco-Roman city was overgrown by vegetation and forgotten for 1,000 years. Marvel at the features of the spectacular site, including defensive walls, the remains of three Doric-style temples and a host of ruins.

🌐 **AHI Connects: Meet the People.** Following a tasty lunch of local dishes, meet some residents of Paestum. Enjoy an engaging dialogue as they



discuss their lifestyles and experiences in Italy.

Enrichment: The Wonders of Naples' National Museum. Learn about this renowned museum and its fascinating collections of art and riveting artifacts.

Day 5 | Naples

Naples and the Museo Archeologico Nazionale.

Energetic Naples, the capital city of Campania, welcomes visitors with a vivacious spirit. Gain insight into the ancient world at the Museo Archeologico Nazionale. The museum's galleries boast one of the largest collections of Greco-Roman artifacts in the world. Continue on a panoramic tour of Naples, taking in sprawling views of the city and the Bay of Naples from atop Posillipo Hill. Note the landmarks of Castel Nuovo, San Francesco di Paola, Teatro di San Carlo and Piazza del Plebiscito.

Indulge in authentic Neapolitan pizza for lunch. The savory flavors of this local specialty are unbeatable!

Day 6 | Vietri sul Mare

Free Time: Join the Elective Activity on the Isle of Capri or stay in Vietri sul Mare for a day at leisure.

Elective | The Isle of Capri. Travel by hydrofoil to the enchanting Isle of Capri, beloved by artists and writers through the centuries. Enjoy a private boat ride around the island, witnessing the Faraglioni rocks and pretty grottos. Back on land, stroll along Capri's scenic lanes, visit the Gardens of Augustus or snack on gelato and other delicious treats.

Enrichment: The Horror and Splendor of Mount Vesuvius. Learn about the tragic effects of the first-century eruption of Mount Vesuvius.

Day 7 | Herculaneum | Pompeii

Herculaneum and Pompeii. Spend the day exploring these captivating Roman cities. The small town of Herculaneum was preserved by mudflows while Pompeii was covered by ash. The preservation of the cities is unlike anything else in the world. Today, they are famous as an excavation site and outdoor museum



that reveal how the people of this ancient Roman settlement lived 2,000 years ago. From mosaics to furniture to frescoes, unearth a captivating history lesson as you tour the Forum, baths and houses.

Enrichment: Contemporary Italy. Discuss Italian society and the current situation in Italy. Savor Italy's delectable dishes during dinner tonight.

Day 8 | Sorrento

Green Side of Sorrento. Travel inland where skilled agriculturists have a passion for their land. At a farm, tour groves of olive trees, learn how fresh-picked olives are ground into delicious olive oils and see how to make *fior di latte*, a semi-soft cheese. Sample this traditional treat and other local products.

Free Time: Spend the afternoon at leisure. Browse for souvenirs from the many boutiques and shops.

Raise a toast to your Italian adventure as you gather for a Farewell Reception and Dinner tonight.

Day 9 | In Transit

Transfer to the airport in Naples for the return flight to your gateway city.

Included Features

Accommodations (with baggage handling)

- 7 nights in Vietri sul Mare, Italy at the first-class Hotel Raito.

Extensive Meal Program

- 7 breakfasts, 3 lunches and 4 dinners, including Welcome and Farewell Dinners; tea or coffee with all meals, plus wine with dinner.
- Opportunities to sample authentic, local cuisine.

Your One-of-a-Kind Journey

- **Small group:** Sized just right at 28 guests.
- **AHI Travel Assurance** covers Accident and Sickness Medical Expense, Trip Delay and Emergency Evacuation for U.S. residents.
- **Enrichment by expert speakers** enhances your insight into the region.
- **Engaging excursions** showcase the local culture, heritage and history.
- **Electives** and free time to pursue your individual interests.
- **AHI Sustainability Promise:** We strive to make a positive impact wherever we travel.
- **AHI Connects:** Local immersion.
- Welcome and Farewell Receptions to mingle with fellow travelers.
- A personal VOX headset to hear your English-speaking guide clearly.
- Tipping of guides and drivers.
- Complimentary travel mementos.



2024 Departures & Pricing

May 29 – June 6, 2024

Full Price from	\$4,245
Special Savings	\$250
Special Price from	\$3,995*

*Special price available for a limited time. Call for details.
 VAT & port tax supplement are an additional \$295 per person.
 All prices quoted are in USD, per person, based on double occupancy and do not include air transportation costs (unless otherwise stated).
 Single accommodations are an additional \$795 (limited availability).
 Program-specific terms and conditions are available at <https://ucla.ahitravel.com/destinations/1820A?schoold=170>. You can also request a copy from our travel experts.
Note: Itinerary sequence and/or scheduled events may change. Walking is required on many excursions.
 Flights and transfers provided for AHI FlexAir participants.
 Electives available at an additional cost.



Italy's Magnificent Lake District

Inspiring Moments

- ▶ Indulge in glorious views of cobalt lakes, snowcapped mountains and opulent villas while cruising on **Italy's spectacular lakes**.
- ▶ Glide along tranquil **Lake Orta** and experience the enchantment of the legendary Isola San Giulio.
- ▶ Admire the stunning **Borromean Islands** and enjoy a special private reception on Isola Bella.
- ▶ Learn from local chefs during a **private farm-to-table cooking class**.
- ▶ **Savor lunch in Bellagio** and a walk in this terraced lakeside village known for its beautiful silk.
- ▶ Sip bubbly Prosecco while mingling with locals and admiring views from your **hotel's rooftop lounge**.
- ▶ Witness **"The Last Supper,"** Leonardo da Vinci's brilliant fresco-style painting, a **UNESCO World Heritage site**.



Bellagio

Experience Italy's lauded lakes district, a haven of sapphire waters and dreamy foothills. Here, the shores are strung with medieval churches and elegant 19th-century villas — an inviting region to experience *la dolce vita!* From your base in Stresa, venture out to picturesque islands and romantic villages. Visit tranquil botanical gardens, fragrant with sweet flowers, and marvel at Leonardo da Vinci's masterpiece, "The Last Supper." Plus, join a chef and learn how to prepare Italian cuisine during a fun cooking lesson with a local family. Italy awaits to surprise and delight you!

Day-by-Day Itinerary

Day 1 | In Transit

Depart for Milan, Italy 🌐

Day 2 | Milan, Italy | Stresa

Arrive in Milan, transfer 🚗 to Stresa and check in to the Hotel La Palma.

This evening, join your fellow travelers for a Welcome Reception and Welcome Dinner at the hotel.

Day 3 | Stresa | Lake Orta

Enrichment: *The Development of the Lake District.*

Learn about Italy's captivating Lake District, a haven of Alpine peaks, gardens and lakes.

Lake Orta. Enjoy a scenic drive to Orta San Giulio, built on a promontory that juts into the lake. During a walking tour, see the central piazza and soak up the charms of idyllic lakeside life. Board a boat and cruise to Isola San Giulio, the enchanted island in the lake. Soak up the history and beauty of the Romanesque basilica, the island's landmark attraction.

Free Time: Craft your own path in San Giulio. Follow narrow lanes, pausing to marvel at the village's colorful houses and small chapels.

Gather for an Italian dinner. Popular local dishes include stuffed pastas, seafoods and locally grown vegetables.

Day 4 | Borromean Islands

Enrichment: *The Gardens of Lake Maggiore.*

Learn about the powerful Borromeo family and how they transformed the tranquil islands — that now are named after them — into splendid retreats featuring palaces and landscaped gardens.

Free Time: Get to know Stresa at your own pace.

Borromean Islands. Begin your outing on Lake Maggiore aboard a private boat. Cruise to Isola Madre where you'll enjoy a guided tour of the extensive botanical gardens. Embrace the rustic charm of Isola dei Pescatori, a peaceful fishing village. Continue to

ALUMNI CAMPUS
ABROAD®



Isola Bella, “The Beautiful Island,” and enjoy an exclusive visit. These stunning grounds feature a palatial palace and gardens filled with fragrant citrus trees, water-wheel towers, statues and peacocks. Delight in a private reception in the island’s terraced hanging gardens. Savor some tasty aperitifs while appreciating this slice of Italian paradise.

Day 5 | Bellagio | Como

Bellagio. Start your day with a boat ride on Lake Como to Bellagio. Known as the Pearl of Lake Como, this photogenic destination greets visitors with its inviting setting. Be captivated by the promenade lined with lime trees and flower boxes, the quaint city center, and charming buildings painted in shades of cream and butterscotch. After exploring this enchanting village, relax over lunch at a lakeside restaurant.

Free Time: Discover Bellagio on your own during leisure time. Take a romantic stroll along the waterfront or pause for a treat at a requisite gelato stand.

Cruising Lake Como. Travel by private boat from Bellagio to Como, a sensational way to experience the region. Glide on blue waters bathed in sunlight while viewing the graceful villas and villages nestled along the shores. Vistas of stunning gardens, hidden waterfalls and cypress groves will captivate your senses while the majestic Alps stand sentry in the background. This poetic boat ride is sure to be among your treasured memories! Arrive in Como and take a walking tour.

Day 6 | Stresa

Enrichment: Golden Age of the Renaissance.

Delve into the true genius of Michelangelo and Leonardo da Vinci while tracing their profound influences on sculpture and painting.

AHI Connects: Flavors of Italy. Learn the secrets of northern Italian cuisine during an interactive cooking lesson from a local family. After, dig into a delicious lunch overlooking Lake Maggiore.

Free Time: Spend the remainder of the day at leisure. Soak up a sunset by the harbor or settle in at a local café for a light snack or cocktail.

Enrichment: Contemporary Italy. Discuss Italy’s economy, politics and role in the European Union.



Day 7 | Milan

A Cultural Visit to Milan. Travel to Milan, Italy’s economic powerhouse. The city’s wealth of cultural heritage is showcased in its architecture, art and prestigious museums. Visit the exquisite Renaissance Church of Santa Maria delle Grazie to see Leonardo’s remarkable “The Last Supper,” hailed as one of the world’s greatest paintings. See the flamboyant 14th-century Duomo, a masterpiece defended by 2,244 marble saints and nearly 100 scowling gargoyles. Continue to the museum at the legendary La Scala, Italy’s opulent, premier opera house.

Free Time: Spend time at leisure having lunch and getting to know cosmopolitan Milan.

Day 8 | Stresa

Free Time: There are endless opportunities to pursue your own interests during a day at leisure.

Raise a toast to your Italian adventure during a festive Farewell Reception and Farewell Dinner.

Day 9 | In Transit

Transfer to the Milan airport for the return flight to your gateway city.

Included Features

Accommodations (with baggage handling)

- 7 nights in Stresa, Italy, at the first-class Hotel La Palma.

Extensive Meal Program

- 7 breakfasts, 2 lunches and 3 dinners, including Welcome and Farewell Dinners; tea or coffee with all meals, plus wine with dinner

Your One-of-a-Kind Journey

- **Small group:** Sized just right at 28 guests.
- **AHI Travel Assurance** plan covers Accident and Sickness Medical Expense, Trip Delay and Emergency Evacuation for U.S. residents.
- **Enrichment by expert speakers** enhances your insight into the region.
- **Engaging excursions** showcase the local culture, heritage and history.
- **AHI Sustainability Promise:** We strive to make a positive impact wherever we travel.
- **AHI Connects:** Local immersion.
- Free time to pursue your individual interests.
- Welcome and Farewell Receptions to mingle with fellow travelers.
- A personal VOX headset to hear your English-speaking guide clearly.
- Tipping of guides and drivers.
- Complimentary travel mementos.



2024 Departures & Pricing

June 13-21, 2024

Garden View Price	\$4,345
Special Savings	\$250
Special Garden View Price	\$4,095*

*Special price available for a limited time. Call for details.

VAT & port tax supplement are an additional \$295 per person.

All prices quoted are in USD, per person, based on double occupancy and do not include air transportation costs (unless otherwise stated).

Single prices are available upon request (limited availability).

Program-specific terms and conditions are available at <https://ucla.ahitravel.com/destinations/1816A?schoold=170>. You can also request a copy from our travel experts.

Note: Itinerary sequence and/or scheduled events may change. Walking is required on many excursions.

Flights and transfers provided for AHI FlexAir participants.

Electives available at an additional cost.



Tuscany & Emilia-Romagna

A Cultural & Culinary Journey

Inspiring Moments

- ▶ Unravel the **culinary paradise of Emilia-Romagna** within its timeless towns of Bologna, Parma and Modena.
- ▶ Discover foods famous the world over during visits to a **cheese farm, olive mill and country winery**.
- ▶ Roam history-soaked cobblestones in **Castell'Arquato and Vigoleno**.
- ▶ Encounter the **University of Bologna**, the oldest university in the Western world.
- ▶ **Sample "liquid black gold,"** the aceto balsamico tradizionale di Modena.
- ▶ Indulge in heavenly **Parma flavors** of parmesan cheese and pasta.
- ▶ Fall under Tuscany's alluring spell and **linger in Orvieto**, a hilltop Umbrian town.
- ▶ Experience the Porticoes of Bologna, a **UNESCO World Heritage site**.

ALUMNI CAMPUS
ABROAD®



Parmesan cheese

Sensational beauty and gastronomy await on this eight-night Italian adventure! Enjoy stays in Parma and Cortona and uncover the spirit, culture and heritage of Italy's delightful Emilia-Romagna and Tuscany regions. From Bologna's storied *porticoes* to Parma's lauded cathedral, charming medieval villages to beautiful country farms, these destinations will seduce all your senses. Along the way, savor culinary favorites, including balsamic vinegar, parmesan cheese and pasta. Plus, sip and swirl locally made wines at a Tuscan winery and hone your cooking skills while learning to make typical regional dishes.

Day-by-Day Itinerary

Day 1 | In Transit

Depart for Milan, Italy. 🌐

Day 2 | Milan, Italy | Parma

Arrive in Milan, transfer 🚗 to Parma and check in to the Sina Maria Luigia hotel.

Later tonight, gather with your fellow travelers for a Welcome Reception and Dinner.

Day 3 | Parma

Parma Walking Tour. The day begins with a discovery of wonderful Parma! Perhaps most famous for its delicious ham and cheese, Parma is also packed with regal palaces, gardens and storied landmarks. During a walking tour, see the Parma Cathedral and the Teatro Regio di Parma, the performance home of composer Giuseppe Verdi. Also pass by the Palazzo della Pilotta and through the Piazza Garibaldi.

🌐 **AHI Connects | Parma's Pastas.** Join an expert for a hands-on pasta cooking class. Learn the techniques behind making egg-based and stuffed pastas. After, try your creations as you dig into a tasty lunch!

Free Time: Make your own plans in Parma. Stroll through Parco Ducale or sip wine at an outdoor café.

Day 4 | Parma | Vigoleno | Castell'Arquato

Cheese Farm, Vigoleno & Castell'Arquato. Head out to the country to visit a cheese farm. During an intimate tour, learn how expert cheese makers turn milk, salt and rennet into sensational parmesan cheese. After lunch, step back in time along the medieval streets of Vigoleno. Lauded as one of Italy's most compelling villages, Vigoleno is home to a well-preserved fortified castle and the Romanesque Church of San Giorgio. Continue to pretty Castell'Arquato and see the town's highlights on a walking tour.

Enrichment: Culinary & Cultural History of Emilia-Romagna.



Included Features

Accommodations {with baggage handling}

- **4 nights** in Parma, Italy, at the first-class Sina Maria Luigia.
- **4 nights** in Cortona at the first-class Villa Marsilli.

Transfers {with baggage handling}

- Deluxe motor coaches transfers during the Land Program.

Extensive Meal Program

- 8 breakfasts, 4 lunches and 3 dinners, including Welcome and Farewell Dinners; tea or coffee with all meals, plus wine with dinner.

Your One-of-a-Kind Journey

- **Small group:** Sized just right at 28 guests.
- **AHI Travel Assurance** plan covers Accident and Sickness Medical Expense, Trip Delay and Emergency Evacuation for U.S. residents.
- **Enrichment by expert speakers** enhances your insight into the region.
- **Engaging excursions** showcase the local culture, heritage and history.
- **PYJ | Personalize Your Journey**
A choice of excursions in selected locales.
- **AHI Sustainability Promise:** We strive to make a positive impact wherever we travel.
- **AHI Connects:** Local immersion.
- Welcome and Farewell Receptions to mingle with fellow travelers.
- A personal VOX headset to hear your English-speaking guide clearly.
- Tipping of guides and drivers.
- Complimentary travel mementos.



Day 5 | Parma | Modena

PYJ | Choose one of the following excursions:

- **Ferrari Museum in Maranello.** Venture to Maranello to encounter the beloved Italian sports car brand. Take a guided panoramic tour of the Ferrari estate and view the outside of the Ferrari workshops and plants. Learn about the history of the car at the Ferrari Museum.
- **Reggio Emilia Walking Tour.** Get to know this lovely, laid-back city on a walking tour. Pass by the imposing Santa Maria cathedral, the old Jewish Ghetto, the Basilica di San Prospero and the baroque Basilica della Ghiara.

Balsamic Vinegar of Modena. Discover where true Balsamic vinegar hails from at the Acetaia Tenuta Medici. Learn about the maturation, refinement and aging process of aceto balsamico tradizionale di modena. Savor a tasting of this sweet yet savory syrup.

AHI Connects | Traditional Farm Visit. Continue to a traditional farmhouse for a memorable dinner. Enjoy authentic dishes produced from ingredients grown on the land.

Day 6 | Parma | Bologna | Cortona

Begin your journey to Cortona via Bologna.

Bologna. “La Rossa” beckons with searing red buildings and historic covered arched arcades. A walking tour showcases the Piazza Maggiore, the Town Hall and the Archiginnasio di Bologna. Look above to see the city’s symbolic towers.

Arrive in Cortona and check in to your hotel.

Day 7 | Cortona

Cortona Walking Tour and the Museum of the Etruscan Academy. While passing historic palazzos and piazzas, admire Cortona’s exceptional Etruscan features. Pass by the Piazza della Repubblica and see the 13th-century town hall and the prominent Museo Diocesano. Discover jaw-dropping vistas of fertile olive groves and Lake Trasimeno from the ancient porta. Next, visit the Praetorian Palace. Inside, the Museum of the Etruscan Academy boasts rare archaeological finds and Etruscan, Roman and Egyptian works of art.

Enrichment: Contemporary Italy.



Day 8 | Cortona | Orvieto

A Taste of Umbria in Orvieto. Orvieto stands sentry over the green Umbrian countryside. Join a guide along the cobblestone streets, stopping to visit the Gothic-Romanesque Duomo that boasts a brilliant façade rendered in marble and colorful mosaics.

AHI Connects | Olive Oil Mill & Museum. Head into the rolling hills to a family-run olive mill. Discover how the family creates mouthwatering olive oils. Enjoy the buttery flavors of this specialty.

Day 9 | Cortona | Montalcino

Tuscan Countryside and Altesino Winery. Travel through the patchwork of burgeoning hill country, blanketed with shimmering olive groves, bucolic farmsteads, cypress trees and red poppy playgrounds. Enjoy a culinary experience at a family-owned winery in the Brunello di Montalcino region. Tour the winery and sample vintages and tasty local cheeses.

Raise a toast during a Farewell Reception and Dinner.

Day 10 | In Transit

Transfer to the Florence airport for the return flight to your gateway city.

2024 Departures & Pricing

September 10-19, 2024

Full Price from	\$4,545
Special Savings	\$250
Special Price from	\$4,295*

*Special price available for a limited time. Call for details.
VAT & port tax supplement are an additional \$395 per person.
All prices quoted are in USD, per person, based on double occupancy and do not include air transportation costs (unless otherwise stated).
Single accommodations are an additional \$695 (limited availability).
Program-specific terms and conditions are available at <https://ucla.ahitravel.com/destinations/1796A?schoollid=170>. You can also request a copy from our travel experts.
Note: Itinerary sequence and/or scheduled events may change. Walking is required on many excursions.
Flights and transfers provided for AHI FlexAir participants.
Electives available at an additional cost.



Spain

Andalucía | In a Parador

Inspiring Moments

- ▶ Ponder the influence of the Moors as you explore the enchanting **Alhambra**.
- ▶ Clap to the rhythm of a soulful **flamenco performance**.
- ▶ Immerse yourself in the charm of **Antequera**, nestled in Andalucía's picturesque heartland.
- ▶ Marvel at the breathtaking view of El Tajo Gorge in **Ronda**.
- ▶ Delight in the majestic architecture of the cathedral and Alcázar in **Sevilla**.
- ▶ Sip a glass of wine at a **countryside bodega** as you savor your adventure in Andalucía.
- ▶ Experience four **UNESCO World Heritage sites**.

ALUMNI CAMPUS
ABROAD®

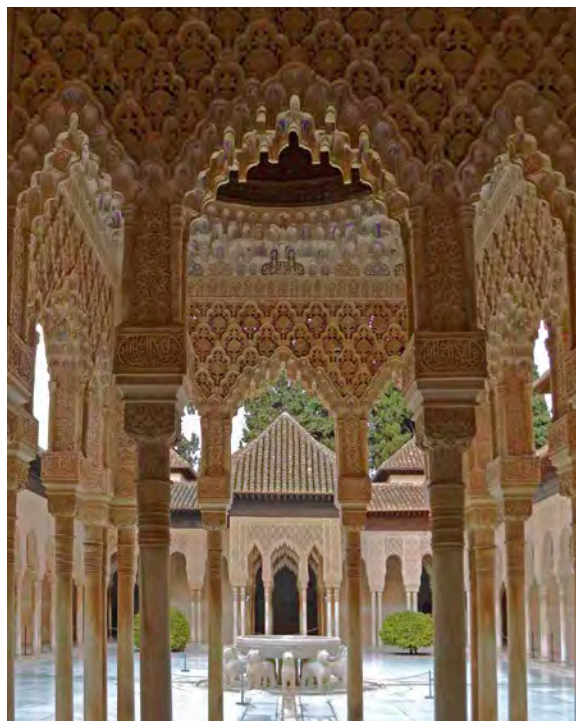

Court of the Lions, Alhambra, Granada

Embrace the romantic spirit of southern Spain on this enriching, seven-night journey in Andalucía! Settle in for the week at a modern parador in lovely Antequera and then set off on engaging excursions throughout the region. Learn how Andalucía's heritage has been shaped by a fascinating mix of cultures and religions as you encounter its spectacular treasures. Take in magnificent palaces, imposing fortresses, remarkable prehistoric tombs and an awe-inspiring mosque-cathedral. Other memorable moments await! Gaze over the impressive El Tajo Gorge, taste flavorful Spanish wines and relish an impassioned flamenco!

Day-by-Day Itinerary

Day 1 | In Transit

Depart for Málaga, Spain. 🚗

Day 2 | Málaga, Spain | Antequera

Transfer 🚗 to the Parador de Antequera.

At the parador tonight, get acquainted with your fellow travelers at a Welcome Reception and Dinner.

Day 3 | Antequera

Ancient Antequera. The prehistoric Menga and Viera dolmens were built by farmers in the valley between 3500 and 3000 B.C. On a guided tour of this UNESCO World Heritage site, imagine the labor and skill involved in constructing these immense stone burial chambers. Then, embark on a guided walk in Antequera. Start at the Alcazaba, the 14th-century Moorish fortress that once guarded the city, where you'll enjoy sweeping views. Continue into the old town to admire its historic landmarks and stop for lunch after your walk.

Free Time: Set your own agenda this afternoon.

Enrichment: *Andalucía and the Moorish Influence.*

Day 4 | Granada

The Palace City of Alhambra. Travel today to the Alhambra, a UNESCO World Heritage site, in Granada. This exquisite Moorish palace complex and fortress was built in the 13th and 14th centuries by the kings of the Nasrid dynasty who sought to create their own paradise on earth. Admire intricately filigreed courtyards and halls in the Palacios Nazaries, walk through the fortress and stroll in the gardens of Generalife. Relax later over lunch at the Parador de Granada within the Alhambra.

Day 5 | Sevilla

Sevilla. Journey to the cultural heart of southern Spain. On a scenic/walking tour, see the centuries-old bullring and the Moorish watchtower near the river. Next, tour the grand Real Alcázar, a medieval Moorish palace still in use today as a royal residence, and see the stunning



Cathedral of Sevilla, the world's largest Gothic church. Together, they are a UNESCO World Heritage site. End with a walk in the charming Barrio de Santa Cruz and time for lunch on your own. As you return to Antequera, visit the splendid Plaza de España, built in 1929 for an international exhibition, which features a canal and tiled alcoves representing the provinces of Spain. Tonight, dine with your fellow travelers at the parador.

Day 6 | Ronda

Ronda. Spectacularly set above El Tajo Gorge over the open countryside, Ronda is a showstopper and the largest of Andalucía's *pueblos blancos*, or white towns. Begin your guided walk at the bullring, Plaza de Toros, established in 1785. Stand in the arena and delve into the dramatic world of bullfighting at its museum. Later, soak up marvelous views of Ronda from the terrace of Casa de San Juan Bosco. Cap off your Ronda visit with a tour of the beautiful Iglesia de Santa María la Mayor.

AHI Connects: Bodega Lunch & Tasting. Sample fine wines and enjoy lunch at a winery near Ronda.

Day 7 | Córdoba

Córdoba. A UNESCO World Heritage site, Córdoba's mosque-cathedral, La Mezquita, contains the finest examples of Moorish architecture in Spain. While the mosque was built in the eighth century, the cathedral was erected in the 16th century after Spanish forces recaptured Córdoba in 1236. Its combination of Islamic and Christian decorative elements dazzles the eye, including the prayer hall of striped arches, the golden mihrab, the altar screen and the mahogany choir stalls. Afterward, see the Roman bridge over the Guadalquivir

River, and walk along the Jewish quarter's winding lanes lined with whitewashed houses.

Free Time: Select a nice spot for lunch in Córdoba.

This evening, join your group for a delectable dinner at a restaurant in Antequera. After your meal, appreciate the emotion and precision of flamenco, Spain's famous art form, during a special performance.

Day 8 | Antequera

Enrichment: Contemporary Spain.

Free Time: Spend your last day at leisure in Antequera. Another option is to take the complimentary, round-trip shuttle to vibrant Málaga and make your own plans. You can also choose to join today's Elective Activity.

Elective | El Torcal & Olive Oil Experience. Marvel at the otherworldly, limestone formations of El Torcal de Antequera Nature Park on a drive. Take a coffee break there and, if you'd like, walk to see the rocks up close. Head next to a family-owned olive oil mill for a tour and a delicious brunch featuring their freshly pressed oils.

Celebrate your time in the south of Spain tonight at a Farewell Reception and Dinner in the parador.

Day 9 | In Transit

Transfer to the airport in Málaga for the return flight to your gateway city.

Included Features

Accommodations (with baggage handling)

– **7 nights** in Antequera, Spain, at the first-class Parador de Antequera.

Extensive Meal Program

– 7 breakfasts, 3 lunches and 4 dinners, including Welcome and Farewell Dinners; tea or coffee with all meals, plus wine with dinner.

Your One-of-a-Kind Journey

- **Small group:** Sized just right at 28 guests.
- **AHI Travel Assurance** plan covers Accident and Sickness Medical Expense, Trip Delay and Emergency Evacuation for U.S. residents.
- **Enrichment by expert speakers** enhances your insight into the region.
- **Engaging excursions** highlight the local culture, heritage and history.
- **Electives** and free time to pursue your individual interests.
- **AHI Sustainability Promise:** We strive to make a positive impact wherever we travel.
- **AHI Connects:** Local immersion.
- Welcome and Farewell Receptions to mingle with fellow travelers.
- A personal VOX headset to hear your English-speaking guide clearly.
- Tipping of guides and drivers.

NO SINGLE SUPPLEMENT for Solo Travelers



2024 Departures & Pricing

September 19-27, 2024

Full Price from	\$3,245
Special Savings	\$250
Special Price from	\$2,995*

*Special price available for a limited time. Call for details. VAT & port tax supplement are an additional \$295 per person. All prices quoted are in USD, per person, based on double occupancy and do not include air transportation costs (unless otherwise stated).

Single supplement waived for solo travelers! This offer is limited, capacity-controlled and tends to sell out quickly. Program-specific terms and conditions are available at <https://ucla.ahitravel.com/destinations/1788A?schoolid=170>. You can also request a copy from our travel experts.

Note: Itinerary sequence and/or scheduled events may change. Walking is required on many excursions.

Flights and transfers provided for AHI FlexAir participants. Electives available at an additional cost.



Chilean Wonders

Lake District & Patagonia

Inspiring Moments

- ▶ Be awed by the jaw-dropping grandeur of **Torres del Paine National Park**, one of the world's most beautiful natural wonderlands.
- ▶ Revel in the vitality of **cosmopolitan Santiago**, framed by snowcapped Andean peaks.
- ▶ Marvel at majestic, blue-hued glaciers in the pristine wilderness of **Chilean Patagonia**.
- ▶ Savor the splendor and tranquility of **Chile's Lake District**.
- ▶ Dig into delicious, sizzling specialties hot off the grill at a **Chilean asado**.
- ▶ Experience a **UNESCO Biosphere Reserve**.



Plaza de Armas, Santiago

On this remarkable adventure, connect with the wild nature and warm culture of Chile, where each region of this slender South American jewel reveals fascinating contrasts. In vibrant Santiago, relish the capital's lively streets, tantalizing cuisine and architectural gems. Next, journey south to the lovely Lake District to soak up the serene scenery and delight in penguins off Chiloé Island. Then, bask in the magnificence of Patagonia's fabled fjords and glaciers near the end of the world!

Day-by-Day Itinerary

Day 1 | In Transit

Depart for Santiago, Chile. 🌐

Day 2 | Santiago, Chile

Transfer 🔄 to the Hotel Cumbres Lastarria.

Enrichment: Chilean History.

Gather for tonight's Welcome Reception and Dinner.

Day 3 | Santiago

Santiago. Explore this dynamic city with interesting commentary from your guide. At the Museo de la Memoria y los Derechos Humanos, grasp the human cost of Chile's turbulent history with exhibits on the human rights violations of the military dictatorship from 1973–1990. Then, on a scenic tour, admire the Palacio de la Moneda and Plaza de Armas. Linger in hip Bellavista, buzzing with cafés and art galleries, where Pablo Neruda, the Nobel laureate poet, once lived.

Free Time: Make plans of your own this afternoon. Be sure to try tasty, classic dishes like *empanadas* and *pastel de choclo*, a flavorful corn pudding.

Enrichment: Contemporary Chile.

Day 4 | Puerto Montt | Puerto Varas

Depart for the airport and fly to Puerto Montt. After you arrive, head to a small fishing village for an authentic *curanto* lunch. Then, travel to Puerto Varas and check in to the Enjoy Puerto Varas Hotel on Lake Llanquihue. Join your group for dinner in the hotel tonight.

Day 5 | Chiloé Island

Chiloé Island. Ferry to this picturesque island and stop in Chacao to stroll through its town square and see the church. Next, watch Humboldt and Magellanic penguins and other wildlife from a boat that takes you close to their natural habitats. Enjoy lunch after the cruise. Later, visit a museum in Ancud to learn about the island's wooden churches built by 17th-century Spanish Jesuit missionaries.

ACTIVE TRAVEL 🚶

Excursions on this program require:

- ▶ walking distances of up to 3–5 miles
- ▶ walking on cobblestones, unpaved paths and/or uneven surfaces
- ▶ getting on/off motor coaches and boats



Day 6 | Petrohué River Falls | Puerto Varas

Petrohué River Falls. Breathtaking scenery is the star attraction today within Vicente Pérez Rosales National Park. Admire the turquoise waters of the falls and navigate by boat through stunning Lake Todos los Santos surrounded by snowcapped volcanoes. Afterward, relax over a delectable Chilean *asado*, or barbecue, at a nearby restaurant.

Free Time: Enjoy some leisure time in Puerto Varas.

Enrichment: *The History of the Patagonia.*

Day 7 | Puerto Montt | Punta Arenas | Puerto Natales

After breakfast, transfer to Puerto Montt's airport and fly to Punta Arenas.

Punta Arenas. On a scenic tour, see the highlights of this historic port city on the Strait of Magellan.

Continue to Puerto Natales and check in to the Hotel Costaustralis along the waterfront. After getting settled, dine with your fellow travelers at a local restaurant.

Day 8 | Puerto Natales

Balmaceda and Serrano Glaciers. Take in vistas of emerald hillsides, waterfalls and rugged mountains as you cruise on the Ultima Esperanza Fjord to view Balmaceda, a hanging glacier. Then, follow your guide on an invigorating walk amid the unspoiled beauty of Bernardo O'Higgins National Park and see the spiky Serrano glacier. Savor lunch at a Patagonian ranch, and cruise back to Puerto Natales.

Day 9 | Torres del Paine National Park

Torres del Paine National Park. Spectacular scenery awaits you on a scenic drive in this 935-square-mile park, a UNESCO Biosphere Reserve. Its astonishing landscape encompasses rolling valleys, mirrorlike lakes, snowcapped summits and the craggy granite peaks, the Torres del Paine, or Towers of Paine. An abundance of wildlife, including condors, guanacos, Andean deer and pumas, adds to the park's allure. Along your route, see the Salto Grande waterfall and enjoy lunch.



Day 10 | Punta Arenas | Santiago

This morning, depart for the airport in Punta Arenas for your flight to Santiago. Check in to the Hotel Cumbres Lastarria.

This evening, gather for a festive Farewell Dinner in honor of your memorable Chilean adventure!

Day 11 | Santiago

Free Time: Create your own agenda in Santiago or join today's Elective Activity.

Elective | Viña del Mar and Valparaíso. Travel to pretty Viña del Mar, a favorite vacation getaway of Chileans, known for its broad beaches. Then, delight in the quirky charms of oceanside Valparaíso, a UNESCO World Heritage site. See its historic squares and hills packed with a jumble of colorful houses, funiculars and vivid street art. Ride up Cerro Bellavista with free time for lunch and exploring.

Tonight, transfer to Santiago's airport for your return flight to your gateway city. Based on flight schedules, some travelers may arrive home today.

Day 12 | In Transit

Arrive home in your gateway city.

Included Features

Accommodations {with baggage handling}

- **3 nights** in Santiago, Chile, at the first-class Hotel Cumbres Lastarria.
- **3 nights** in Puerto Varas at the first-class Enjoy Puerto Varas Hotel.
- **3 nights** in Puerto Natales at the first-class Hotel Costaustralis.



Transfers {with baggage handling}

- All transfers in the Land Program: flights and deluxe motor coaches.

Extensive Meal Program

- 9 breakfasts, 5 lunches and 4 dinners, including Welcome and Farewell Dinners; tea or coffee with all meals, plus wine with dinner.

Your One-of-a-Kind Journey

- **Small group:** Sized just right at 28 guests.
- **AHI Travel Assurance** plan covers Accident and Sickness Medical Expense, Trip Delay and Emergency Evacuation for U.S. residents.
- **Enrichment by expert speakers** enhances your insight into the region.
- **Engaging excursions** showcase the local culture, heritage and history.
- **Electives** to pursue your individual interests.
- **AHI Sustainability Promise:** We strive to make a positive impact wherever we travel.
- Welcome Reception to mingle with fellow travelers.
- A personal VOX headset to hear your English-speaking guide clearly.
- Tipping of guides and drivers.
- Complimentary travel mementos.



2024 Departures & Pricing

December 2-13, 2024

Full Price	\$5,545
Special Savings	\$250
Special Price	\$5,295*

*Special price available for a limited time. Call for details.

VAT is an additional \$395 per person.

All prices quoted are in USD, per person, based on double occupancy and do not include air transportation costs (unless otherwise stated).

Single accommodations are an additional \$995 (limited availability).

Program-specific terms and conditions are available at <https://ucla.ahitravel.com/destinations/1794A?schoolid=170>. You can also request a copy from our travel experts.

Note: Itinerary sequence and/or scheduled events may change. Walking is required on many excursions.

Flights and transfers provided for AHI FlexAir participants.

Electives available at an additional cost.



Croatia & Cruising the Dalmatian Coast

Inspiring Moments

- ▶ Fall under the spell of the **Dalmatian Coast** where glistening blue waters, timeless beauty and alluring islands await.
- ▶ Bask in unrivaled relaxation during a **glorious seven-night Adriatic cruise**.
- ▶ Stroll through the unique landscape of **Plitvice Lakes National Park**.
- ▶ Embrace the natural grandeur and well-preserved history of Adriatic island gems: **Rab, Hvar and Korčula**.
- ▶ Stand amid the magnificent Roman ruins of **Diocletian's Palace in Split**.
- ▶ Witness **Trogir's** Romanesque, baroque and Renaissance-style architecture.
- ▶ Explore a rich abundance of history and culture in beautiful **Dubrovnik**.
- ▶ Uncover the energetic **Croatian capital of Zagreb**.
- ▶ Experience six **UNESCO World Heritage sites**.

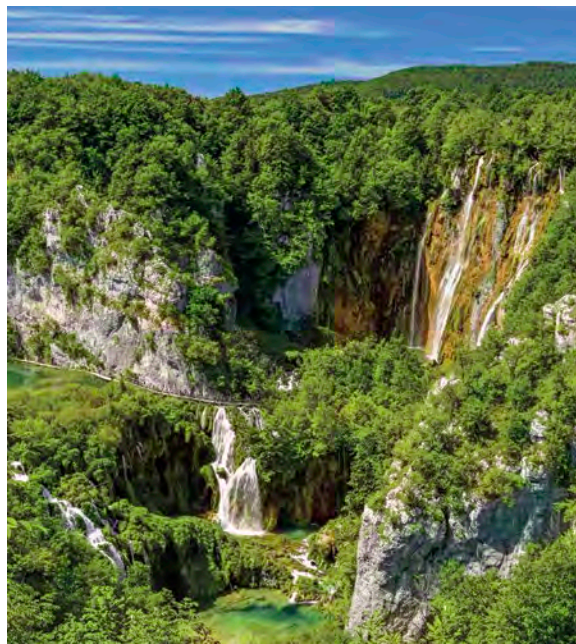

Plitvice Lakes National Park

Discover the bounty of Croatia on this incredible 10-night journey, including a seven-night Adriatic cruise! Explore one of the world's best-preserved medieval towns in legendary Dubrovnik. Then set sail along the Dalmatian coast on your first-class ship to enchanting islands and timeless ports. Walk along cobblestones brimming with maritime legends and see landscapes that stir your soul. Choose between touring the Cathedral of St. James or Krka National Park in Šibenik. Plus, revel in the wonders of Plitvice Lakes National Park, an astonishing natural marvel, before capping off your adventure in cosmopolitan Zagreb.

Day-by-Day Itinerary

Day 1 | In Transit

Depart for Dubrovnik, Croatia. 🌐

Day 2 | Dubrovnik, Croatia

Upon arrival, transfer 🚗 to the ship. Later, join the group and the captain for a Welcome Reception and Dinner.

Day 3 | Dubrovnik | Korčula

Enchanting Dubrovnik. Encounter the majestic Pile Gate and witness Europe's oldest working pharmacy. See the Franciscan Monastery's cloister, pass by the columns of medieval Sponza Palace and view a baroque cathedral with its vast collections of art and religious relics. After, you may wish to walk along the ancient walls to see Dubrovnik's iconic orange rooftops. Begin cruising along the stunning Dalmatian coast, a landscape of dramatic limestone cliffs.

Korčula. The spectacular "Emerald Isle" juts into the Pelješac Channel and brims with natural beauty. Discover Korčula's stunning old town, cobbled lanes and enduring architecture with a guide.

Day 4 | Hvar | Split

Hvar Island. Uncover Hvar, home to a Renaissance cathedral and an ancient community theater. Visit a Benedictine convent that is dedicated to the island's storied tradition of agave lace, an extremely intricate lace made by extracting threads from the agave plant. Continue sailing on gentle seas to Split.

Split. Behold the riches of Split! Roam the courtyards and chambers of Diocletian's Palace. See the Cathedral of Saint Domnius, the Golden Gate and the Peristyle, a rectangular open court that was the heart of the palace.

Day 5 | Trogir | Šibenik

Trogir. Fall under the spell of Trogir, one of Europe's best-preserved Romanesque-Gothic towns. See the Cathedral of St. Lawrence, the intricate Cipiko Palace and the 15th-century Fortress Kamerlengo.



🌐PYJ | Choose one of the following excursions:

- **Cultural Šibenik.** Discover the architecture of Šibenik while visiting the lauded Cathedral of St. James.
- **Krka National Park.** Explore waterfalls, walking paths and more on a journey to this delightful park. (Active)

Day 6 | Zadar

Zadar. This storied university town features the impressive Roman Forum and the St Donat church. Witness the town's modern attractions at its waterfront promenade, including the Sea Organ, a musical art installation. Nearby is the Monument to the Sun, which celebrates Zadar's incredible sunsets. Pause to taste Maraschino cherry liquor and locally made sweets!

Day 7 | Rab Island

Rab Island. Get to know the island's many marvels, from medieval walls and ancient stone lanes to bell towers and pretty squares. Spy local artists painting in outdoor settings and taste *Rapska torta*, or Rab cake. Legend claims that the cake was first served in 1177 to Pope Alexander III.

Day 8 | Krk Island | Opatija

Krk Island. Cruise to Krk Island, Croatia's largest island. Take in views of the city while enjoying lunch on the ship.

Continue sailing to Opatija. Later, raise a toast to your sailing adventure at a Farewell Reception and Dinner.

Day 9 | Opatija | Plitvice Lakes National Park | Zagreb

After breakfast, disembark the ship in Opatija. Head inland to tour Plitvice Lakes National Park.

Plitvice Lakes National Park. Thrill to Croatia's natural sensation boasting 16 crystal-clear terraced lakes linked by a series of waterfalls. The area features a network of boardwalk trails, nearly 160 species of birds and numerous plant species.

Enjoy a lunch of regional dishes, then continue to Zagreb and check in to the Esplanade Zagreb Hotel.

Day 10 | Zagreb

Free Time: Make your own discoveries in Zagreb today



or join our elective excursion to the countryside.

🌐Elective | Croatian Countryside. Travel to Klanjec to visit the Antun Augustincic Museum and Gallery. See some of the famous artist's works and learn about his life before continuing to Kumrovec near the Sulta River. The village features an open-air museum with houses from the end of the 19th century and the beginning of the 20th century. Enjoy lunch at a family restaurant.

Day 11 | Zagreb

Enrichment: Contemporary Croatia.

Zagreb Panoramic Tour. Zagreb weaves European elegance with a Balkan spirit. After a panoramic tour of the lower town, drive to Mirogoj Cemetery, designed by architect Hermann Bollé. Tour the cemetery, then return to Zagreb's beautifully preserved upper town, home to more treasures by Bollé, including St. Mark's Church.

Free Time: Your final afternoon is at leisure. Consider visiting a museum or a deliciously fun farmer's market. Gather for a celebratory Farewell Reception and Dinner.

Day 12 | In Transit

Transfer 🚗 to the airport for the return flight 🛫 to your gateway city.

Included Features

Accommodations {with baggage handling}

- Cruise for **7 nights** aboard the first-class MV Infinity.
- **3 nights** in Zagreb, Croatia, at the deluxe Esplanade Zagreb Hotel.

Transfers {with baggage handling}

- Deluxe motor coach transfers during the Land | Cruise Program.

Extensive Meal Program

- 10 breakfasts, 7 lunches and 4 dinners, including Welcome and Farewell Dinners; tea or coffee with all meals, plus wine with dinner.

Your One-of-a-Kind Journey

- **AHI Travel Assurance** covers Accident and Sickness Medical Expense, Trip Delay and Emergency Evacuation for U.S. residents.
- **Enrichment by expert speakers** enhances your insight into the region.
- **Engaging excursions** showcase the local culture, heritage and history.
- **🌐Personalize Your Journey | PYJ |** A choice of excursions in selected locales.
- **🕒Electives** and free time to pursue your individual interests.
- **🌱AHI Sustainability Promise:** We strive to make a positive impact wherever we travel.
- Free time to pursue your individual interests.
- Welcome and Farewell Receptions to mingle with fellow travelers.
- A personal VOX headset to hear your English-speaking guide clearly.
- Tipping of guides and drivers.

NO SINGLE SUPPLEMENT for Solo Travelers



2024 Departures & Pricing

September 13-24, 2024

Full Price from	\$6,045
Special Savings	\$250
Special Price from	\$5,795*

***See page 48 for complete category pricing.**

*Special price available for a limited time. Call for details.

VAT & port tax supplement are an additional \$395 per person.

All prices quoted are in USD, per person, based on double occupancy and do not include air transportation costs (unless otherwise stated).

Single supplement waived for solo travelers! This offer is limited, capacity-controlled and tends to sell out quickly.

Program-specific terms and conditions are available at <https://ucla.ahitravel.com/destinations/1810A?schoolid=170>. You can also request a copy from our travel experts.

Note: Itinerary sequence and/or scheduled events may change. Walking is required on many excursions.

Flights 🛫 and transfers 🚗 provided for AHI FlexAir participants.

🌐Electives available at an additional cost.



Cruise the Rhine & Moselle Rivers

Amsterdam to Basel

Inspiring Moments

- ▶ Revel in **Amsterdam's wonderful ambience** as you float along its picturesque Golden Age canals.
- ▶ Feel enveloped in the **Rhine Valley's enchanting scenery** of hilltop castles, vine-laced slopes and medieval towns.
- ▶ Be awed by the Gothic grandeur of **Cologne Cathedral**, a masterpiece of human achievement more than 600 years in the making.
- ▶ Delight in the Alsatian flavor of Grande île, **Strasbourg's historic heart**.
- ▶ Take in the **serene Moselle River valley** from the castle high above Cochem.
- ▶ Experience five **UNESCO World Heritage sites**.

ALUMNI CAMPUS
ABROAD®

EXTEND YOUR STAY

Amsterdam | 2 Nights | PRE-Trip

Interlaken | 2 Nights | POST-Trip

{See page 52-53 for details.}



Amsterdam

Enjoy an intimate view of European history on this enriching journey to the Netherlands, Germany and France! Embark on a carefree, seven-night cruise that reveals the cultural riches of Old World cities and towns along storied rivers. You'll relish the beauty and vibrancy along Amsterdam's iconic canals, marvel at magnificent cathedrals in Cologne, Speyer and Strasbourg, and cruise through the legendary Rhine Gorge. Plus, tailor your experience with a choice of engaging, included excursions, such as museum visits, hiking, biking and culinary tours, in Amsterdam, Rudesheim, Heidelberg and Strasbourg!

Day-by-Day Itinerary

Day 1 | In Transit

Depart for Amsterdam, Netherlands. 🌐

Day 2 | Amsterdam, Netherlands

Upon arrival, transfer 🚗 to the pier and embark the ship.

Enrichment: Contemporary Europe.

Canals of Amsterdam. Board a cruiser for a delightful perspective of this beguiling city, known for its more than 60 miles of tree-lined canals and waterways. Admire the gabled houses, locals of all ages pedaling by and the architecture of the bustling harbor.

Day 3 | Amsterdam

🌐 **PYJ | Choose one of the following excursions:**

- **Rijksmuseum.** View fabulous art representing 800 years of Dutch history, including national treasures by Rembrandt, Vermeer and Hals, among others.
- **Waterland Bicycle Ride.** Embrace the Dutch cycling culture and ride through the lush Waterland area dotted with historic fishing villages. *(Active)*
- **Jordaan District Walking and Food Tour.** Pop into shops in this trendy district to try Dutch treats like sweet *poftertjes*, *kibbeling* and fresh cheeses.

Enjoy lunch on the ship, followed by some free time. Gather for tonight's Welcome Reception and Dinner.

Day 4 | Cologne, Germany

Free Time: Relax and enjoy the onboard amenities as the ship cruises along the Rhine River toward Cologne.

Cologne Walking Tour. View the old town's historic landmarks and the cathedral's impressively ornamented exterior. Then, step inside to see the stone columns soaring up to the vaulted ceiling. After your guided walk, shop or linger in a café.

The ship departs Cologne this evening.

Day 5 | Moselle River | Cochem

This morning, the ship cruises through a narrow portion



of the Moselle River flanked by colorful villages and tiered vineyards and then docks in Cochem.

Frühshoppen. On board the ship, delight in this traditional German treat: a tasty glass of beer served with fresh pretzels, sausages and mustards.

Cochem and the Reichsburg Castle. Beautifully situated along a bend in the Moselle, Cochem charms with half-timbered houses, winding streets and hilltop Reichsburg Castle overlooking the town. Learn about its rich folklore on a guided walk and tour the castle.

Day 6 | Koblenz | Rhine Gorge | Rudesheim

The ship arrives in Koblenz this morning.

Koblenz. More than 2,000 years ago, the Romans established a settlement at the confluence of the Moselle and Rhine Rivers, the spot now occupied by lovely Koblenz. See the Church of Our Lady, the Jesuitenplatz and other highlights on a guided walk.

Have your camera ready as the ship sails through the Upper Middle Rhine Valley, a splendid, gently curving stretch with more than 40 castles and fortress ruins.

Enrichment: Castles and Legends of the Rhine.

PYJ | Choose one of the following excursions:

• **Wines of the Rhine.** Ride a tram amid the vineyards near Rudesheim and along bustling Drosselgasse in the old town, then sample fine wines at a winery.

• **A Musical Walk in Time.** Ride a tram amid the vineyards near Rudesheim and along bustling Drosselgasse, then visit a captivating museum of self-playing, mechanical musical instruments.

The ship cruises overnight toward Mannheim.

Day 7 | Mannheim | Heidelberg | Speyer

The ship docks in Mannheim this morning.

PYJ | Choose one of the following excursions:

• **Heidelberg Castle and Town.** Visit the grand, hillside castle overlooking the Neckar Valley, and take an easygoing walk in the romantic old town.

• **Hike Heidelberg's Philosopher's Way.** Hike up this famous path to the Philosopher's Garden and relish gorgeous views and some snacks. (Active) Return to the ship for lunch and cruise to Speyer.



Speyer Walking Tour. Admire the stately Romanesque cathedral, the burial place of emperors for almost 300 years; the 13th-century Old Gate; and other sites in the center of one of Germany's oldest cities.

Day 8 | Strasbourg, France

The ship arrives in the capital of France's Alsace region.

PYJ | Choose one of the following excursions:

• **Strasbourg Panorama.** See the city's blend of German and French influences on a guided scenic tour/walk, and visit Notre Dame Cathedral.

• **Strasbourg Canal Cruise and Petite France Walking Tour.** Discover this charming quarter by boat and on foot, and visit Notre Dame Cathedral.

• **Culinary Strasbourg.** Sample authentic Alsatian dishes and wines in *winstubs*, small wine pubs, and other shops, and visit Notre Dame Cathedral.

Free Time: Savor an afternoon at leisure as the ship sails toward Basel, Switzerland.

This evening, share in a festive Farewell Reception and Dinner with your fellow travelers.

Day 9 | Basel, Switzerland | In Transit

Disembark the ship in Basel. Transfer to the airport in Zürich for the return flight to your gateway city.

Included Features

Accommodations (with baggage handling)

– **Unpack once** and cruise for **7 nights** aboard the **exclusively chartered**, first-class MS Amadeus Queen.

Extensive Meal Program

– 7 breakfasts, 6 lunches and 7 dinners, including Welcome and Farewell Dinners; tea or coffee with all meals, plus wine, beer or soft drinks with lunch and dinner.

Your One-of-a-Kind Journey

– **AHI Travel Assurance** plan covers Accident and Sickness Medical Expense, Trip Delay and Emergency Evacuation for U.S. residents.

– **Enrichment by expert speakers** enhances your insight into the region.

– **Engaging excursions** showcase the local culture, heritage and history.

– **Personalize Your Journey | PYJ |** A choice of excursions in selected locales.

– **Electives** and free time to pursue your individual interests.

– **AHI Sustainability Promise:** We strive to make a positive impact wherever we travel.

– Welcome and Farewell Receptions to mingle with fellow travelers.

– A personal VOX headset to hear your English-speaking guide clearly.

– Tipping of guides and drivers.

– Complimentary travel mementos.

NO SINGLE SUPPLEMENT for Solo Travelers



2024 Departures & Pricing

August 20-28, 2024

Full Price from **\$4,045**

Special Savings **\$250**

Special Price from \$3,795*

***See page 49 for complete category pricing.**

*Special price available for a limited time. Call for details.

VAT & port tax supplement are an additional \$395 per person.

All prices quoted are in USD, per person, based on double occupancy and do not include air transportation costs (unless otherwise stated).

Single supplement waived for solo travelers! This offer is limited, capacity-controlled and tends to sell out quickly.

Program-specific terms and conditions are available at <https://ucla.ahitravel.com/destinations/1812A?schoolid=170>. You can also request a copy from our travel experts.

Note: Itinerary sequence and/or scheduled events may change. Walking is required on many excursions.

Flights and transfers provided for AHI FlexAir participants.

Electives available at an additional cost.



Dutch Waterways

Antwerp to Amsterdam

Inspiring Moments

- ▶ Glide past elegant, gabled houses from the Dutch Golden Age on **Amsterdam's picturesque canals**.
- ▶ Marvel at the **glorious springtime display of tulips** and other cheerful blooms at Keukenhof Gardens.
- ▶ Delight in the romantic, cozy ambience of **canal-lined Bruges**, packed with wonderfully preserved Gothic architecture.
- ▶ Admire **Antwerp's medieval treasures** in the colorful old town.
- ▶ Take in the beautiful façades of charming **Kampen**, a historic Hanseatic city.
- ▶ Enjoy the relaxed pace of life in the Dutch **seaside harbor town of Veere**.
- ▶ Experience three **UNESCO World Heritage Sites**.



Keukenhof Gardens

Embark on a carefree, first-class cruise along the intimate waterways of Belgium and the Netherlands, brimming with centuries of history! Witness the iconic canals of Amsterdam, stroll through a sea of brilliant tulips at Keukenhof Gardens and admire the medieval character of Bruges and Antwerp. Other ports of call introduce you to Kampen, rich in Hanseatic heritage, and Veere, a laid-back harbor town. Expert guides and lecturers add context to your daily sightseeing, plus you'll enjoy a choice of included cultural and culinary experiences in selected ports!

Day-by-Day Itinerary

Day 1 | In Transit

Depart for Brussels, Belgium. 🌐

Day 2 | Brussels, Belgium | Antwerp

Upon arrival, transfer 🚗 to the ship in Antwerp.

Antwerp Walking Tour. Located near the North Sea, Antwerp has long been an important center of trade. Discover its medieval architecture on a guided walk in the old town. See the Cathedral of Our Lady, the town hall and the Grote Markt's narrow guild buildings.

Enrichment: Contemporary Belgium.

The ship moors overnight in Antwerp.

Day 3 | Bruges | Middelburg, Netherlands | Veere

🌐 **PYJ | Choose one of the following excursions:**

All excursions include a guided walking tour of Bruges. Stroll through Market Square and see the medieval guild hall buildings, the Basilica of the Holy Blood and the Belfry Tower. Then, continue with your selected tour.

• **Cultural Bruges.** Admire the outstanding artwork at the Groeninge Museum, known for its Flemish Primitive paintings and Flemish expressionist pieces. *(Active)*

• **Bruges and Beer.** Learn about Belgian brewing traditions on a tour of the De Halve Maan Brewery. Take in the sweeping view of Bruges from the roof and sample a glass of freshly brewed beer. *(Active)*

• **Bruges and Belgian Chocolate.** At a chocolatier's shop, delve into the art and history behind Belgian chocolate-making, plus enjoy a tasty sample. *(Active)*

After lunch on your own in Bruges, rejoin the group and meet the ship in Middelburg. As the ship cruises to Veere, gather for a Welcome Reception and Dinner.

Day 4 | Veere | Willemstad

Free Time: Join the half-day Elective Activity or follow your own agenda in Veere for the day.

ALUMNI CAMPUS
ABROAD®

EXTEND YOUR STAY

Antwerp | 2 Nights | PRE-Trip

Amsterdam | 2 Nights | POST-Trip

{See page 52-53 for details.}



🕒 Elective | Neeltje Jans & Delta Expo. Travel to the artificial island of Neeltje Jans and its Delta Expo. Learn about the Delta Works, the huge dams and storm surge barriers that protect the parts of the Netherlands below sea level. Grasp the terrible impact of the disastrous 1953 flood through a riveting, 4-D animation. The ship docks in Willemstad this evening.

Day 5 | The Hague / Delft / Gouda

Enrichment: The Dutch Masters.

🕒 PYJ | Choose one of the following excursions:

- **The Hague and the Mauritshuis.** See the city's highlights including the Binnenhof, the center of Dutch politics, and the Peace Palace. Next, visit the famed Mauritshuis, which houses Vermeer's "Girl with a Pearl Earring" and artwork by Dutch and Flemish masters.
- **Old Delft and the Porcelain Factory.** Explore historic Delft on a guided walk, then take a tour of the Royal Delft Porcelain Factory, founded in 1653. Watch as a master artisan hand-paints their iconic blue-and-white pottery and view a lovely collection of antique porcelain.
- **Gouda — City of Cheese.** See Gouda's lively market square and its 15th-century town hall, then visit Sint Janskerk, the country's longest church, featuring some of Europe's finest, 16th-century painted-glass windows. Afterward, nibble on varieties of fresh Gouda cheese.

Enjoy lunch on the ship and an afternoon of cruising toward Kampen.

Day 6 | Kampen / Giethoorn

Arrive in Kampen, packed with splendid architecture from its heyday as a medieval Hanseatic trading town.

🕒 PYJ | Choose one of the following excursions:

- **Historic Kampen & Hanseatic Ship Tour.** See the 14th-century Church of St. Nicholas, stately merchants' houses, the grand old town hall and more on a guided walk. Then, visit an authentic replica of a 14th-century, Hanseatic *kogge* cargo ship at the riverfront.
- **Kampen Walking Tour & Brewery Visit.** With your guide, see the 14th-century Church of St. Nicholas, stately merchants' houses, the grand old town hall and more. Savor some Dutch beer later on a brewery tour.



• **Giethoorn Cruise.** Travel by boat along the tiny canals of this quaint, car-free village and explore more on foot. Return to the ship for a delicious lunch.

Enrichment: The Hanseatic League.

Free Time: Spend some time at leisure in Kampen before the ship sails toward Amsterdam this evening.

Day 7 | Amsterdam

Enrichment: Contemporary Netherlands.

Canals of Amsterdam. Take a guided cruise to admire the historic canal houses and other architectural gems. Savor lunch with your fellow travelers.

Free Time: Head off to explore this vibrant city! The ship will remain in Amsterdam overnight.

Day 8 | Amsterdam

Keukenhof Gardens. Explore this 80-acre paradise of brightly colored tulips, hyacinths, daffodils and other gorgeous blooms with your guide.

Return to the ship for a refreshing lunch.

Free Time: Make plans of your own this afternoon. Tonight, gather for a festive Farewell Reception and Dinner on the ship to commemorate your journey.

Day 9 | In Transit

Transfer to the airport for the return flight to your gateway city.

Included Features

Accommodations (with baggage handling)

- Unpack once and cruise for **7 nights** aboard the **exclusively chartered**, first-class MS Amadeus Riva.

Extensive Meal Program

- 7 breakfasts, 5 lunches and 7 dinners, including Welcome and Farewell Dinners; tea or coffee with all meals, plus wine, beer or soft drinks with lunch and dinner.

Your One-of-a-Kind Journey

- **AHI Travel Assurance** plan covers Accident and Sickness Medical Expense, Trip Delay and Emergency Evacuation for U.S. residents.
- **Enrichment by expert speakers** enhances your insight into the region.
- **Engaging excursions** showcase the local culture, heritage and history.
- **🕒 Personalize Your Journey | PYJ |** A choice of excursions in selected locales.
- **🕒 Electives** and free time to pursue your individual interests.
- **🌱 AHI Sustainability Promise:** We strive to make a positive impact wherever we travel.
- Welcome and Farewell Receptions to mingle with fellow travelers.
- A personal VOX headset to hear your English-speaking guide clearly.
- Tipping of guides and drivers.
- Complimentary travel mementos.

NO SINGLE SUPPLEMENT for Solo Travelers



2024 Departures & Pricing

April 3-11, 2024

Full Price from	\$3,645
Special Savings	\$250
Special Price from	\$3,395*

***See page 50 for complete category pricing.**

*Special price available for a limited time. Call for details.

VAT & port tax supplement are an additional \$395 per person.

All prices quoted are in USD, per person, based on double occupancy and do not include air transportation costs (unless otherwise stated).

Single supplement waived for solo travelers! This offer is limited, capacity-controlled and tends to sell out quickly.

Program-specific terms and conditions are available at <https://ucla.ahitravel.com/destinations/1805A?schoolid=170>. You can also request a copy from our travel experts.

Note: Itinerary sequence and/or scheduled events may change. Walking is required on many excursions.

Flights and transfers provided for AHI FlexAir participants.

🕒 Electives available at an additional cost.

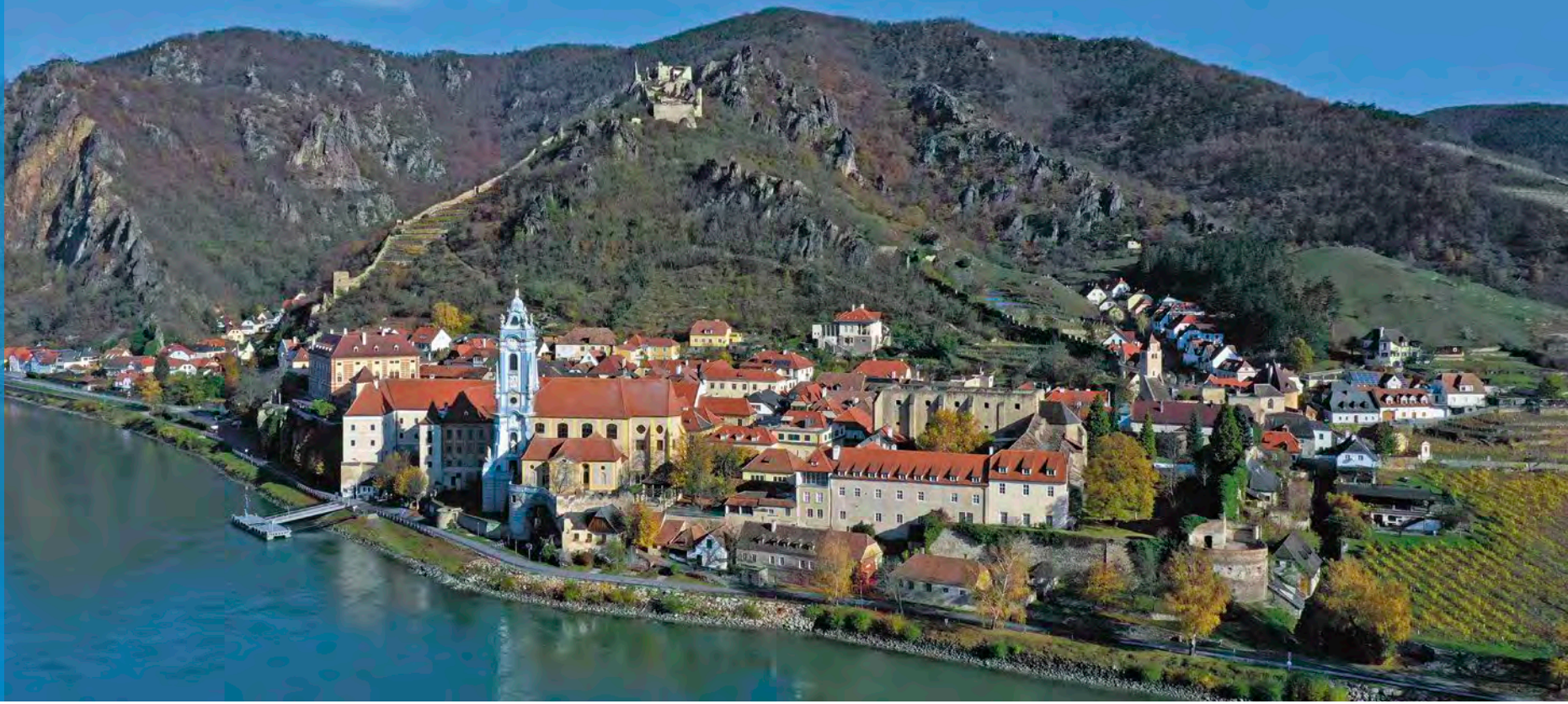

Grand Danube Passage

Prague to Sofia

Inspiring Moments

- ▶ Witness Budapest's glowing, amber skyline during an **evening cruise on the Danube.**
- ▶ Gaze at the scenic wonder of the **Iron Gate Gorge**, an engineering marvel.
- ▶ Discover the history and grandeur of **timeless Vienna, once the heart of an empire.**
- ▶ Delight in the medieval streets and colorful buildings of **Bratislava's old town.**
- ▶ Applaud the grace of elegant dancers during a **special Viennese Waltz performance.**
- ▶ Marvel at the lush, storybook landscape of the **Wachau Valley.**
- ▶ Pause to reflect on the many intricate details and baroque beauty of the **Melk Abbey.**
- ▶ Revel in the **romantic nostalgia of Prague** and stroll along the atmospheric Charles Bridge.
- ▶ Experience five **UNESCO World Heritage sites.**

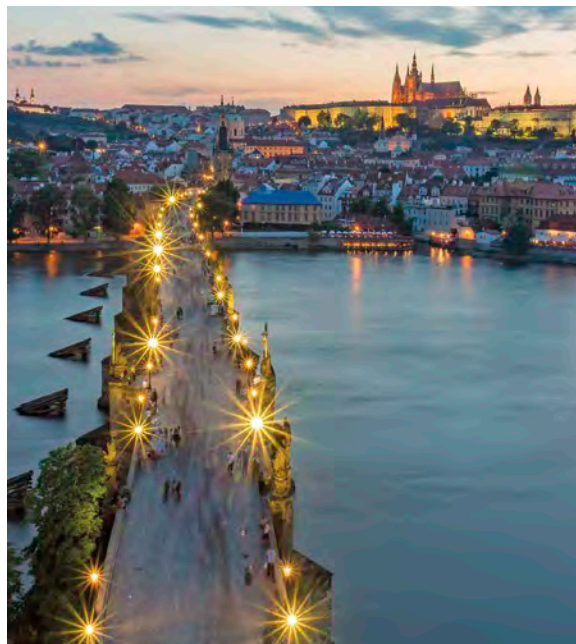

Charles Bridge, Prague

Explore eight countries, Old World capitals and charming villages along the mighty Danube River. Begin in Prague, Czech Republic, set sail on the storied Danube River, and conclude your adventure in Sofia, Bulgaria. Uncover the history of ancient Roman ruins, castles and fortresses, and feast your eyes on an illuminated Budapest, the lush Wachau Valley and the Iron Gate Gorge. Aboard your ship, delight in a Serbian folk show, an authentic German Frühschoppen and enriching lectures. Plus, select from a choice of included excursions in many ports, featuring local cuisine, cycling, art tours and more!

Day-by-Day Itinerary

Day 1 | In Transit

Depart for Prague, Czech Republic. 🌐

Day 2 | Prague, Czech Republic

Upon arrival, transfer 🚗 to the Art Deco Imperial Hotel.

Free Time: Begin to unravel the magic of Prague. Later, meet fellow travelers at a Welcome Reception.

Day 3 | Prague

Prague. Behold the city's marvelous landmarks, including the famous Clock Tower and Charles Bridge.

Free Time: Spend the balance of the day at leisure.

Day 4 | Prague

🌐 **PYJ | Choose one of the following excursions:**

• **Lobkowitz Palace & Museum.** Browse the palace's stunning masterpieces, relics, weapons and art.

• **Prague's Jewish Quarter.** Explore the Jewish Quarter and the Prague National Jewish Museum.

• **Art Nouveau & Cubist Walking Tour.** Uncover Prague's captivating 20th-century architecture.

Free Time: The afternoon is at leisure in Prague.

Day 5 | Prague | Passau, Germany

Following breakfast, transfer to Passau, Germany.

Picturesque Passau. Gaze upon the Veste Oberhaus, St. Stephen's Cathedral and other memorable sites.

Embark your first-class river ship. Later today, gather for a Welcome Aboard Reception and Dinner.

Day 6 | Melk, Austria | Dürnstein

Melk Abbey. Explore the wonders of Melk's Benedictine abbey, an architectural jewel with a grand position overlooking the Danube River. Sail through the picturesque Wachau Valley today.

🌐 **PYJ | Choose one of the following excursions:**

• **Dürnstein.** Be charmed by Dürnstein's baroque façades, medieval ambience and blue Stiftskirche.



- **Danube Cycling.** Ride gently through the pretty countryside, then break for coffee and cake. (Active)
- **Wachau Winery.** Visit a winery to sample locally produced wines and learn about the industry.

Day 7 | Vienna

Enrichment: Timeless Vienna.

🌐 **PYJ | Choose one of the following excursions:**

- **Imperial Vienna.** Tour the Hofburg Palace's Imperial Apartments, followed by a drive by the Ringstrasse.
- **Klosterneuburg Monastery.** See the monastery's art and treasures, and visit a wine cellar for a tasting.
- **Schönbrunn Palace.** Baroque wonders await at the State Apartments, Hall of Mirrors and gardens.

Free Time: Spend some leisure time making your own discoveries in classic Vienna.

🌐 **AHI Connects: Viennese Waltz.** Delight in a waltz show accompanied by a lively musical trio.

Day 8 | Bratislava, Slovakia

Enrichment: The Velvet Revolution.

🌐 **PYJ | Choose one of the following excursions:**

- **Old Town & Café.** See St. Martin's Cathedral, Michael's Gate and more. Plus, enjoy a typical pastry.
- **Old Town & Music.** View sites steeped in musical history, followed by a recital by a young violinist.
- **Iron Curtain Bike Tour.** Enjoy a leisurely bike tour along the historic Slovak-Austrian border. (Active)

Day 9 | Budapest, Hungary

🌐 **PYJ | Choose one of the following excursions:**

- **Budapest.** Witness Heroes' Square, the Parliament Building, Castle Hill, Fisherman's Bastion and more.
- **Living Local.** Visit the buzzing Great Market Hall. Sample fresh strudel and *palinka*, a local schnapps.
- **Budapest's Jewish Quarter.** View the Great Synagogue and tour the Holocaust Memorial Center.

Budapest by Night. Delight in views of an illuminated cityscape during an evening cruise.

Day 10 | Pécs | Osijek, Croatia | Vukovar

Pécs. Enjoy a walking tour of Pécs, known for its spectacular Roman ruins and Ottoman mosques. Share some stories over a lunch of regional cuisine.

🌐 **AHI Connects: Rural Croatia.** Visit Rural House in a small village. Enjoy tasting popular Slavonian foods and locally produced wines.

Osijek & Vukovar. Stroll along Osijek's cobblestones and take a panoramic tour of Vukovar.

Day 11 | Belgrade, Serbia

Enrichment: Modern Serbia.

🌐 **PYJ | Choose one of the following excursions:**

- **Belgrade City Highlights.** Get to know Belgrade! Witness the Kalemegdan Citadel and other iconic sites.



• **Eating Like a Local.** Taste a fusion of Serbian cuisine and learn about local customs and traditions.

• **Science & Scientist Tour.** Witness informative exhibits at the fascinating Nikola Tesla Museum.

Free Time: Craft your own itinerary in Belgrade.

Folklore Performance. Revel in an energetic folk show that depicts Serbia's cultural heritage.

Day 12 | Iron Gate Gorge

Sail by the dramatic Carpathian Mountains, entering the Iron Gate Gorge, an engineering wonder that is part of the boundary between Romania and Serbia.

Frühshoppen! Gather with friends to sip beer and enjoy *brezeln* (pretzels), *Weißwurst* (sausages) and mustards during a fun, age-old German tradition.

Join a Farewell Aboard Reception and Dinner.

Day 13 | Vidin, Bulgaria | Sofia

Following breakfast, disembark the ship.

Vidin Discovery. See a remarkable mosque and visit the St. Panteleimon Church and Baba Vida Fortress.

Savor lunch with a view at The Rocks restaurant.

Transfer to Sofia. Check in to the Sofia Hotel Balkan.

Day 14 | Sofia

Enrichment: Prologue to the Bulgarian Revival.

Sofia. From its ancient history to its unique geographical location, Bulgaria's capital is a fascinating wonder. Venture out to see St. George Rotunda, Alexander Battenberg Square and more.

Free Time: Pave your own path through Sofia's streets! Join us for a Farewell Reception and Dinner tonight.

Day 15 | In Transit

Transfer 🔄 to the airport for the return flight 🛫 to your gateway city.

Included Features

Accommodations {with baggage handling}

- **3 nights** in Prague, Czech Republic, at the deluxe Art Deco Imperial Hotel.
- **8 nights** aboard the exclusively chartered, first-class MS Amadeus Silver III.
- **2 nights** in Sofia, Bulgaria, at the deluxe Sofia Hotel Balkan.

Transfers {with baggage handling}

- Deluxe motor coach transfers during the Land | Cruise Program.

Extensive Meal Program

- 13 breakfasts, 9 lunches and 9 dinners, including Welcome and Farewell Dinners; tea or coffee with all meals, plus wine, beer or soft drinks with lunch and dinner.

Your One-of-a-Kind Journey

- **Visit 8 countries** during this program.
- **AHI Travel Assurance** plan covers Accident and Sickness Medical Expense, Trip Delay and Emergency Evacuation for U.S. residents.
- **Enrichment by expert speakers** enhances your insight into the region.
- **Engaging excursions** highlight the local culture, heritage and history.
- 🌐 **Personalize Your Journey | PYJ**
A choice of excursions in selected locales.
- 🌱 **AHI Sustainability Promise:** We strive to make a positive impact wherever we travel.
- 🌐 **AHI Connects:** Local immersion.
- Free time to pursue your individual interests.
- Welcome and Farewell Receptions to mingle with fellow travelers.
- A personal VOX headset to hear your English-speaking guide clearly.
- Tipping of guides and drivers.
- Complimentary travel mementos.

NO SINGLE SUPPLEMENT for Solo Travelers

2024 Departures & Pricing

May 18 – June 1, 2024

Full Price from	\$6,145
Special Savings	\$250
Special Price from	\$5,895*

*See page 51 for complete category pricing.

*Special price available for a limited time. Call for details.

VAT & port tax supplement are an additional \$395 per person. All prices quoted are in USD, per person, based on double occupancy and do not include air transportation costs (unless otherwise stated).

Single supplement waived for solo travelers! This offer is limited, capacity-controlled and tends to sell out quickly.

Program-specific terms and conditions are available at <https://ucla.ahitravel.com/destinations/1809A?schoolid=170>. You can also request a copy from our travel experts.

Note: Itinerary sequence and/or scheduled events may change. Walking is required on many excursions.

Flights 🛫 and transfers 🔄 provided for AHI FlexAir participants.



Holiday Markets Cruise

The Festive Rhine River | Basel to Düsseldorf

Inspiring Moments

- ▶ Relax on deck as the **river's glorious scenery unfolds around you**, vistas of clifftop castles, medieval villages and forested hills.
- ▶ Be immersed in the **joyful spirit of the holiday markets** amid festive music, fragrant aromas and colorful pageantry.
- ▶ Enjoy an **exclusive musical treat** in Heidelberg's romantic old town.
- ▶ Delight in the quaint timbered houses and cobbled streets of Grande Île, the **historic heart of Strasbourg**.
- ▶ Gaze upward in awe at the soaring spires of **Cologne Cathedral**.
- ▶ Experience four **UNESCO World Heritage sites**.



Warming up with mulled wine

Celebrate centuries-old traditions at European holiday markets on a seven-night Rhine River cruise to Germany and France. Feel the holiday magic in town squares aglow with twinkling lights and good cheer and overflowing with handmade decorations. Delight in the uplifting sounds of carolers and bells and the scent of nutmeg, cinnamon and fresh pine in the air. New adventures await daily! Visit Heidelberg's red sandstone castle over the Neckar valley and admire Cologne's cathedral built over 630 years. Customize your cruise with a selection of included excursions in Breisach, Strasbourg, Rudesheim and Düsseldorf.

Day-by-Day Itinerary

Day 1 | In Transit

Depart for Zürich, Switzerland. 🌐

Day 2 | Zürich, Switzerland | Basel

Upon arrival, transfer 🚗 to Basel and embark the ship. Get acquainted at a Welcome Reception and Dinner.

Day 3 | Breisach, Germany | Freiburg

Freiburg. Stroll in the historic center of this vibrant university city. See the 13th-century cathedral, the turreted Merchants' Hall and other highlights, then visit the cheery *Christkindlmarkt*.

🌐PYJ | Choose one of the following excursions:

- **Riquewihr and the Wines of the Alsace.** Visit this exquisite French medieval village set in a small valley near the Vosges mountains. Sample some of its fabulous wines and take in its romantic charm.
- **Colmar Markets.** Explore four different Alsatian holiday markets, each with its own character, in this pretty French town lined with half-timbered houses. The ship sails for Strasbourg, France.

Day 4 | Strasbourg, France

The ship moors in the capital of France's Alsace region.

🌐PYJ | Choose one of the following excursions:

- **Strasbourg Panorama.** Witness the city's unique blend of German and French influences as you see top landmarks. Take a guided walk in the historic area and visit the Gothic Notre Dame Cathedral.
 - **Culinary Strasbourg.** Sample traditional Alsatian dishes and wines as you explore the city's *winstubs* (small wine pubs) and other local cafés and shops.
- Free Time:** Catch a complimentary shuttle from the ship to the city center and meander in the luminous wonderland of Strasbourg's *marché de Noël*.
- Enrichment: German Holiday Traditions.** The ship remains docked in Strasbourg this evening.

ALUMNI CAMPUS
ABROAD®

🌐 EXTEND YOUR STAY

Interlaken | 2 Nights | PRE-Trip

Berlin | 3 Nights | POST-Trip

(See page 53 for details.)



Included Features

Accommodations (with baggage handling)

- **Unpack once** and cruise for **7 nights** aboard the **exclusively chartered**, first-class MS Amadeus Imperial.

NO SINGLE SUPPLEMENT
for Solo Travelers

Extensive Meal Program

- 7 breakfasts, 6 lunches and 7 dinners, including Welcome and Farewell Dinners; tea or coffee with all meals, plus wine, beer or soft drinks with lunch and dinner.

Your One-of-a-Kind Journey

- **AHI Travel Assurance** plan covers Accident and Sickness Medical Expense, Trip Delay and Emergency Evacuation for U.S. residents.
- **Enrichment by expert speakers** enhances your insight into the region.
- **Engaging excursions** showcase the local culture, heritage and history.
- **Personalize Your Journey | PYJ |** A choice of excursions in selected locales.
- **AHI Sustainability Promise:** We strive to make a positive impact wherever we travel.
- **AHI Connects:** Local immersion.
- Free time to pursue your individual interests.
- Welcome and Farewell Receptions to mingle with fellow travelers.
- A personal VOX headset to hear your English-speaking guide clearly.
- Tipping of guides and drivers.
- Complimentary travel mementos.

Day 5 | Mannheim, Germany | Heidelberg

The ship arrives in Mannheim early this morning.

Heidelberg Castle and Town. Tour the impressive castle with its immense wine barrel and gaze over Neckar Valley from above. Then walk with your guide in the old town, past the Student Jail, Old University, the cathedral and along the Neckar River. Relax afterward at a traditional German restaurant.

Free Time: Explore the old town on your own.

AHI Connects: Musical Trio. Relish a special and exclusive treat as a professional trio performs holiday songs, arias and contemporary pieces.

Day 6 | Rudesheim | Rhine Gorge

PYJ | Choose one of the following excursions:

• **Rudesheim Tour.** Board a tram and travel along the lively Drosselgasse to visit a captivating museum of self-playing, mechanical musical instruments and the “Christmas Market of the Nations” with holiday items from around the world.

• **Rhine Wine Tasting.** Travel to the beautiful Abbey of St. Hildegard to tour the abbey and church and learn about the remarkable St. Hildegard of Bingen. Later, taste fine vintages at a Rudesheim winery.

Sail through stunning scenery in the Upper Middle Rhine Valley, a gently curving, 40-mile stretch lined with more than 40 castles and fortress ruins.

Tonight on board, gather with your fellow cruisers for a Glühwein party, and savor this spiced winter drink.

Day 7 | Cologne

Cologne Walking Tour. See the old town’s landmarks and visit the majestic cathedral.

After your excursion, savor a tasty lunch on the ship.

Free Time: Enjoy Cologne on your own this afternoon.

Day 8 | Düsseldorf

PYJ | Choose one of the following excursions:

• **Düsseldorf and Holiday Markets.** See the city’s eclectic, eye-catching architecture, including the



Medienhafen riverfront district. Then, explore the old town, famed for a half-mile stretch of more than 250 bars, cafés and breweries. Next, enjoy time to visit the city’s seven themed *Christkindlmarkts*, focused on handicrafts, angels and fairy tales, among others.

• **Aachen, City of Emperor Charlemagne.** Travel to this historic city that was once the capital and favorite royal residence of Charlemagne, crowned emperor of the Romans by Pope Leo III in 800. Tour Aachen’s cathedral, a UNESCO World Heritage site, featuring Charlemagne’s richly decorated imperial chapel and his original throne. Walk through the city center and spa area before finishing at the holiday market.

Return to the ship for a delicious lunch.

Free Time: Explore Düsseldorf and its markets.

Celebrate your magical holiday cruise with your fellow travelers at tonight’s Farewell Reception and Dinner.

Day 9 | In Transit

Transfer to the airport in Düsseldorf for the return flight to your gateway city.



2024 Departures & Pricing

December 4-12, 2024

Full Price from **\$3,245**

Special Savings **\$250**

Special Price from \$2,995*

***See page 51 for complete category pricing.**

*Special price available for a limited time. Call for details.

VAT & port tax supplement are an additional \$395 per person.

All prices quoted are in USD, per person, based on double occupancy and do not include air transportation costs (unless otherwise stated).

Single supplement waived for solo travelers! This offer is limited, capacity-controlled and tends to sell out quickly.

Program-specific terms and conditions are available at <https://ucla.ahitravel.com/destinations/1808A?schoolid=170>. You can also request a copy from our travel experts.

Note: Itinerary sequence and/or scheduled events may change. Walking is required on many excursions.

Flights and transfers provided for AHI FlexAir participants.

Electives available at an additional cost.

Croatia & Cruising the Dalmatian Coast | Land | Coastal Journey

Category-Deck	Full Price	Special Savings	Special Price*
D-Lower	\$6,045	\$250	\$5,795
C-Lower	\$6,245	\$250	\$5,995
B-Main	\$7,145	\$250	\$6,895
A-Upper	\$8,045	\$250	\$7,795

A category features a private balcony and large window. B category features a large window. Categories C and D feature a porthole.

*Special price available for a limited time only. Call for details.

VAT and Port Tax supplement is an additional \$395 per person. All prices quoted are in USD, per person, based on double occupancy and do not include air transportation costs (unless otherwise stated).

Single supplement waived for solo travelers! This offer is limited, capacity-controlled and tends to sell out quickly.

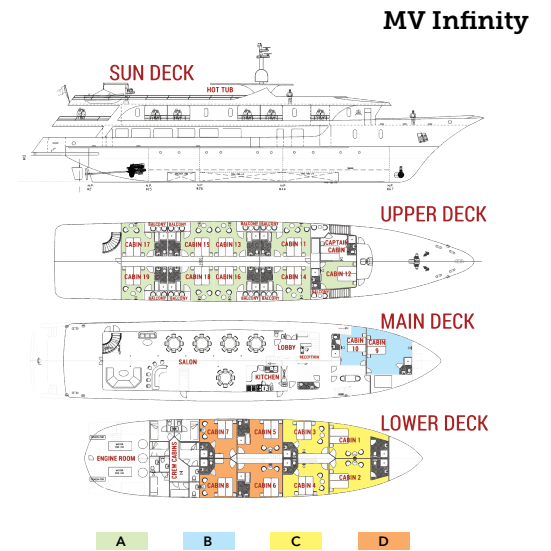
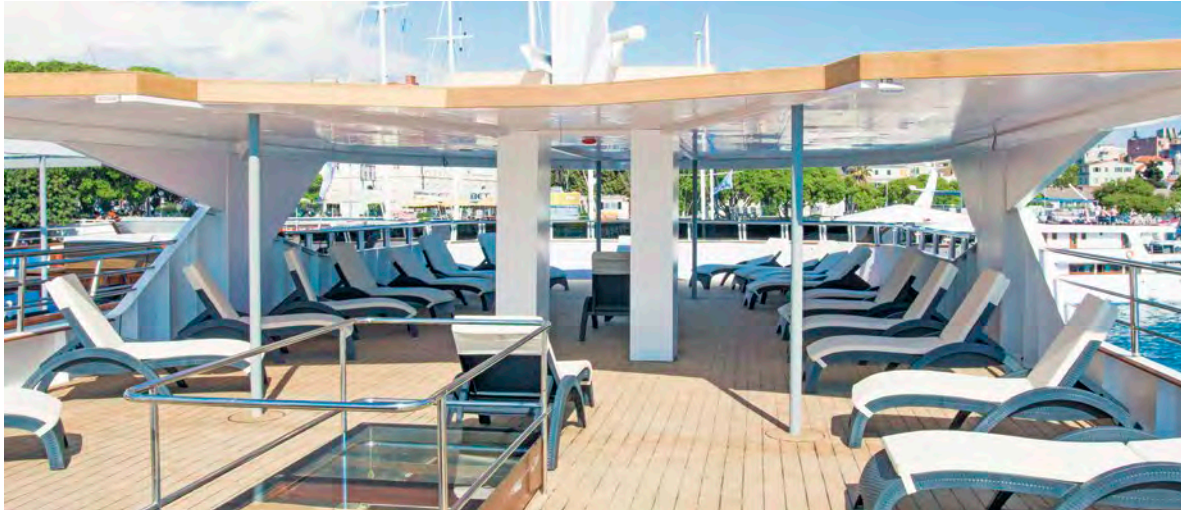

Left: MV Infinity sun deck | Above: MV Infinity cabin
Below: MV Infinity



Cruise the Rhine & Moselle Rivers | River Journey

MS Amadeus Queen

Category-Deck	Full Price	Special Savings	Special Price*
E-Haydn (Mid Aft)	\$4,045	\$250	\$3,795
D-Haydn (Midship)	\$4,245	\$250	\$3,995
C-Strauss (Aft)	\$4,745	\$250	\$4,495
B-Strauss (Midship)	\$4,945	\$250	\$4,695
A-Mozart (Aft)	\$5,445	\$250	\$5,195
Suite-Mozart (Midship)	\$5,945	\$250	\$5,695

Suite category features a balcony. Categories A, B and C feature a drop-down panoramic window. Categories D and E feature a panoramic window.

*Special price available for a limited time only. Call for details.

VAT and Port Tax supplement is an additional \$395 per person. All prices quoted are in USD, per person, based on double occupancy and do not include air transportation costs (unless otherwise stated).

Single supplement waived for solo travelers! This offer is limited, capacity-controlled and tends to sell out quickly.

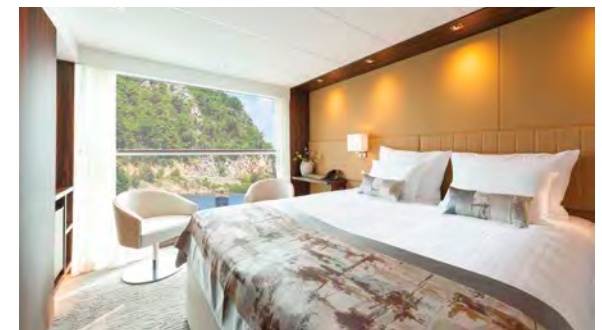
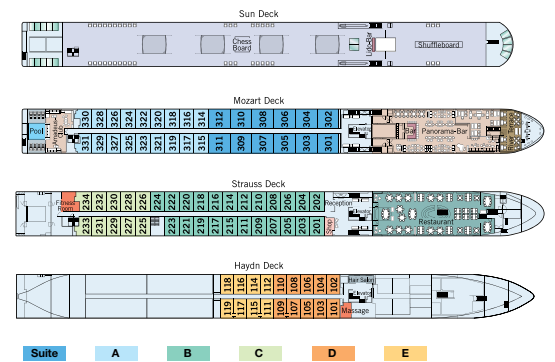
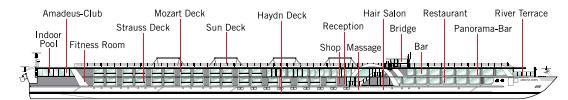

Left: MS Amadeus Queen club | Above: MS Amadeus Queen cabin | Below: MS Amadeus Queen



Dutch Waterways | River Journey

MS Amadeus Riva

Category-Deck	Full Price	Special Savings	Special Price*
E-Haydn (Mid Aft)	\$3,645	\$250	\$3,395
D-Haydn (Midship)	\$3,845	\$250	\$3,595
C-Strauss (Aft)	\$4,245	\$250	\$3,995
B-Strauss (Midship)	\$4,445	\$250	\$4,195
A-Mozart (Aft)	\$4,945	\$250	\$4,695
Suite-Mozart (Midship)	\$5,445	\$250	\$5,195

Suite category features a balcony. Categories A, B and C feature a drop-down panoramic window. Categories D and E feature a panoramic window.

*Special price available for a limited time only. Call for details.

VAT and Port Tax supplement is an additional \$395 per person. All prices quoted are in USD, per person, based on double occupancy and do not include air transportation costs (unless otherwise stated).

Single supplement waived for solo travelers! This offer is limited, capacity-controlled and tends to sell out quickly.

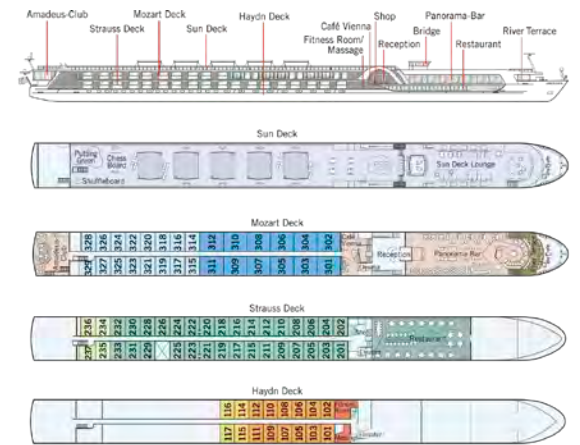

Left: MS Amadeus Riva club | Above: MS Amadeus Riva cabin
Below: MS Amadeus Riva



Grand Danube Passage | River Journey

Category-Deck	Full Price	Special Savings	Special Price*
E-Haydn (Mid Aft)	\$6,145	\$250	\$5,895
D-Haydn (Midship)	\$6,345	\$250	\$6,095
C-Strauss (Aft)	\$6,845	\$250	\$6,595
B-Strauss (Midship)	\$7,045	\$250	\$6,795
A-Mozart (Aft)	\$7,545	\$250	\$7,295
Suite-Mozart (Midship)	\$8,045	\$250	\$7,795

Suite category features a balcony. Categories A, B and C feature a drop-down panoramic window. Categories D and E feature a panoramic window.

*Special price available for a limited time only. Call for details.

VAT and Port Tax supplement is an additional \$395 per person. All prices quoted are in USD, per person, based on double occupancy and do not include air transportation costs (unless otherwise stated).

Single supplement waived for solo travelers! This offer is limited, capacity-controlled and tends to sell out quickly.



MS Amadeus Silver III

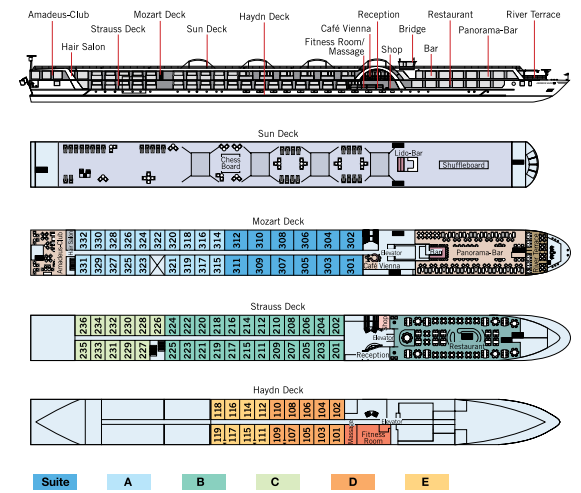

Left: MS Amadeus Silver III
Above: MS Amadeus Silver III cabin

Holiday Markets Cruise | River Journey

Category-Deck	Full Price	Special Savings	Special Price*
E-Haydn (Mid Aft)	\$3,245	\$250	\$2,995
D-Haydn (Midship)	\$3,445	\$250	\$3,195
C-Strauss (Aft)	\$3,945	\$250	\$3,695
B-Strauss (Midship)	\$4,145	\$250	\$3,895
A-Mozart (Aft)	\$4,645	\$250	\$4,395
Suite-Mozart (Midship)	\$5,145	\$250	\$4,895

Suite category features a balcony. Categories A, B and C feature a drop-down panoramic window. Categories D and E feature a panoramic window.

*Special price available for a limited time only. Call for details.

VAT and Port Tax supplement is an additional \$395 per person. All prices quoted are in USD, per person, based on double occupancy and do not include air transportation costs (unless otherwise stated).

Single supplement waived for solo travelers! This offer is limited, capacity-controlled and tends to sell out quickly.



MS Amadeus Imperial

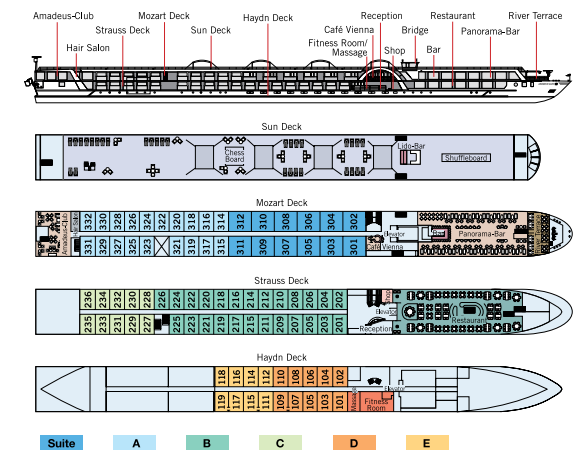

Left: MS Amadeus Imperial
Above: MS Amadeus Imperial cabin

Extend your Stay

Elective Extensions

We have designed extensions on many of our programs to allow you to craft your individual travel experience.

Each Extension Includes:

- All features described in the itinerary overviews
- Centrally located, first-class or deluxe accommodations
- Services of an AHI Travel Director and AHI Hospitality Desk
- Transfers between the ship and the hotel or between hotels with baggage handling, where applicable
- Guide and driver gratuities
- All taxes and service charges
- Free time to explore on your own

{ The programs on which each extension is offered are indicated in brackets. }

"The trip was outstanding from beginning to end – trip directors from AHI couldn't have been better, with their attention to detail and care and enjoyment of each and every person...

All the local guides and bus drivers were excellent. I learned so much about the history and culture of Portugal, of which I knew little before the trip."

Jane | Romance of the Douro

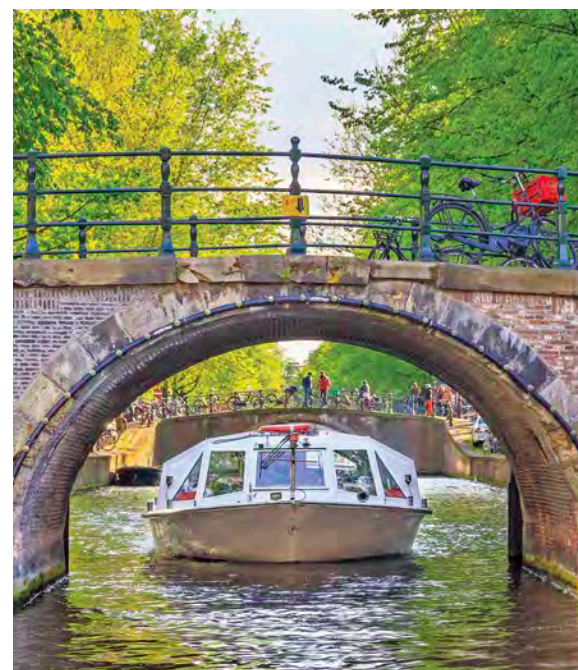

Amsterdam | 2 Nights

{ Dutch Waterways |
Cruise the Rhine & Moselle Rivers }

Get to know picturesque Amsterdam more intimately! From your base right in the heart of the city, explore its lively, bike-filled streets and delightful canals, as well as its renowned museums and attractions. Enjoy a guided walking tour during your stay, plus daily breakfasts.

**\$995 per person, double occupancy |
\$1,470 single occupancy.**



Cape Town | 2 Nights

{ Journey to Southern Africa }

Enjoy more of vibrant Cape Town. Unwind at the deluxe Belmond Mount Nelson Hotel, and embark on a full-day tour of the Cape Winelands, South Africa's famous wine region. Tour the vineyard's cellar and savor a wine and cheese pairing, followed by lunch and a visit to the delightful, historic town of Stellenbosch.

**\$1,295 per person, double occupancy |
\$1,890 single occupancy.**



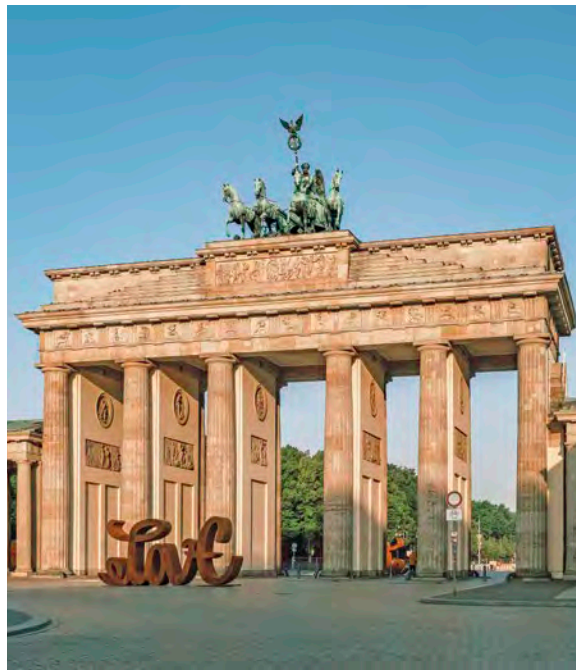

 **Antwerp | 2 Nights**

{ Dutch Waterways }

Settle into a first-class hotel in this vibrant city for extra days of fun! This inviting, walkable city offers plenty of wonderful diversions, from intriguing museums to the simple pleasures of scrumptious treats like Belgian waffles and crispy frites! Plus, marvel at the medieval splendor of Ghent on a guided excursion.

\$995 per person, double occupancy | \$1,395 single occupancy.

 **Berlin | 3 Nights**

{ Holiday Markets Cruise }

Get to know one of Europe's most exciting cities over three nights at a first-class hotel in the heart of the action. See Berlin's top highlights, including the Reichstag, Brandenburg Gate and Checkpoint Charlie, on a scenic tour and spend free time exploring some of the city's 80 holiday markets!

\$1,095 per person, double occupancy | \$1,390 single occupancy.

"My only other group travel experience was AHI's Cuba trip in 2017, which set a very high standard for my expectations. This trip was also outstanding in every way. Nani is outstanding as were all the speakers and guides. Nani's efficiency and warmth ensure that we, as travelers, know that the details are handled and we can enjoy our travels..."

Our experience was a true Greek experience of hospitality and friendship...

Also, the learning aspects were so enriching and rewarding that I am reminded of the value of travel as helping us develop as citizens of the world."

Virginia | Greece



 **Interlaken | 2 Nights**

{ Holiday Markets Cruise }

\$1,195 per person, double occupancy | \$1,590 single occupancy.

{ Cruise the Rhine & Moselle Rivers }

\$1,195 per person, double occupancy | \$1,490 single occupancy.

Immerse yourself in the incredible natural beauty of Switzerland's Bernese Oberland while staying at the deluxe Victoria-Jungfrau Grand Hotel & Spa. Take a guided tour of Bern, and enjoy time at leisure to explore this gorgeous region on your own.



Let us arrange your flights for you



Our experts are ready to assist you in booking flights. Our personalized air program offers the following advantages:

- ▶ A **price guarantee** to protect you from fuel surcharge increases after ticket purchase
- ▶ Arrival and departure **transfers** on group dates
- ▶ **Flexibility** to change or cancel your reservations without penalty up to 60 days before departure on most flights
- ▶ **Assistance** in the event of schedule changes or delays



Travel Insider Program

Your Direct Line to Greater Access & Luxury

Become a Travel Insider and gain access to a vast array of savings opportunities and other travel benefits!

Before booking:

- Enjoy access to AHI Travel experts, including exclusive Travel Insider information.
- Ensure your spot on our most popular programs with advance booking opportunities.
- Receive priority service through a dedicated toll-free number and email address.
- Save hundreds of dollars through special Travel Insider offers.

Book a trip and benefit from:

- Priority response from your Travel Coordinator
- Priority room assignments when possible
- \$100 savings on business class upgrades through select carriers
- No deviation fees
- Exclusive gifts and travel mementos



Visit us at ucla.ahitravel.com and sign up today!



A pledge from AHI Travel

AHI Travel is the premier operator of deluxe educational travel programs. We have been connecting travelers to the people, places and cultures of the world for more than 60 years. Our experienced, professional staff has offered the highest level of service in innovative travel programs since 1962.

In our care, you can rely on:

- ▶ **An exceptional travel value** impossible for an independent traveler to arrange at a comparable price
- ▶ **Preferred access** to local sites
- ▶ **Experienced Travel Directors** who attend to every detail of your journey and provide local expertise
- ▶ **Expert local guides** with extensive regional knowledge and personal insights
- ▶ **Freedom to customize** your experience and pursue your own interests
- ▶ **Enhanced health and safety practices**
- ▶ **Included AHI Travel Assurance** — this plan covers travel- and health-related contingencies for U.S. residents



"Attention to detail is superb!... Truly an enjoyable trip! Our tour director Mary was outstanding! She made the trip absolutely perfect with her expert explanations, guidance and making sure our every need was met... This was our second trip with AHI and we could not be happier. We plan to take many more trips with you and will share our experiences with friends and family. Your company truly is the best! Thank you for making this vacation a truly memorable one for us!"

Carol | Ireland

UCLA

Alumni Travel

Presorted Std.
U.S. Postage
Paid
AHI Travel

UCLA Alumni Association
James West Alumni Center
325 Westwood Plaza
Los Angeles, CA 90095-1397

CATALOG24 2

Committed to connecting travelers to the people, places and cultures of the world for more than 60 years.



Above: UCLA travelers, Croatia | Cover photo: Prague, Czech Republic

SPECIAL OFFER

Act Now
to ensure your place
and still save
\$500 Per Couple!

Please call or visit our website for more information,
to reserve your space or to download a trip brochure.

alumni.ucla.edu/travel | 310.206.0613